



# ***Installation Manual***

---

## ***1964<sup>1</sup>/<sub>2</sub> - 1966 Mustang***

DOCUMENT #1-2025

©2013 ClassicAutoAir / 3.13vs2







# ***Congratulations...***

**You have just purchased the highest quality, best performing A/C system ever designed for your Mustang.**

To obtain the high level of performance and dependability our systems are known for, please pay close attention to the following instructions. Our installation steps and procedures are derived from a long history of research and development and the combined experience achieved thru thousands of successful installations (and feedback from customers like you). Please remember that our #1 goal is that you'll have a successful installation and a system that performs at a very high level for many years to come.

Before starting, read the instructions carefully, from beginning to end, and follow the proper sequence. On the next page you'll find a safety and general checklist that you should read before starting your installation.

Again, thank you from our entire staff.



## Check List, Pre-Installation:

- Before beginning the installation check the shipping box for the correct components. YOUR BOXED UNIT INCLUDES A LIST OF MAJOR COMPONENTS AND A LIST OF BAGGED PARTS. We have a 5 stage check process to make sure you have everything you'll need.
- If your vehicle has been or is being modified, some procedures will need to be adjusted to fit your particular application.**
- A basic cleaning of the engine compartment and interior before beginning will make things go more smoothly.
- Check condition of engine mounts. Excessive engine movement can damage hoses to A/C and/or heater.
- Before starting, check vehicle interior electrical functions (interior lights, radio, horn, etc). Make a note of anything that does not work as it's supposed to. During the installation you might find the opportunity to repair or upgrade non-working or out of date components. When you're ready to start the installation, **DISCONNECT THE BATTERY FIRST.**
- Drain the radiator. Retain the coolant and reuse, or dispose of properly.
- SAFETY FIRST: Wear eye protection while drilling/cutting, deburr sharp edges, and never get in a hurry or force a part.
- Tools: Your installation only requires the basic tools everyone has in their garage, nothing exotic or specific to A/C or Heat equipment.

## Procedures, During Installation:

- Fittings: Use one or two drops of mineral oil (supplied with your kit) on ALL rubber o-rings, threads and where o-rings seat in fittings. Do not use thread tape or sealants.
- Measure twice (or more), cut once
- Should you have any technical questions, or feel you have defective components (or missing items), call us immediately, we will be glad to assist you. Our toll-free number is listed on every page, we're here to help!**

***YOU CAN NOW BEGIN THE INSTALLATION...***

## A Basic Overview of Automotive A/C...

- 1 Evaporator with Blower Fan** In order to remove the heat from the air in the vehicle, the A/C evaporator allows the refrigerant to absorb the heat from the air passing over it. The blower fan moves cool air out into the car interior.
- 2 Compressor** The compressor pumps and circulates the refrigerant through the system.
- 3 Condenser** The condenser is a heat exchanger mounted at the front of the vehicle. Heat drawn out of the interior of the car is expelled here.
- 4 Receiver/Drier** The drier not only dries refrigerant, it also filters the refrigerant and stores it under certain operating conditions.
- 5 High Pressure Switch** A pressure switch is used to shut down the system if high or low pressure is detected, basically it acts as a safety switch.

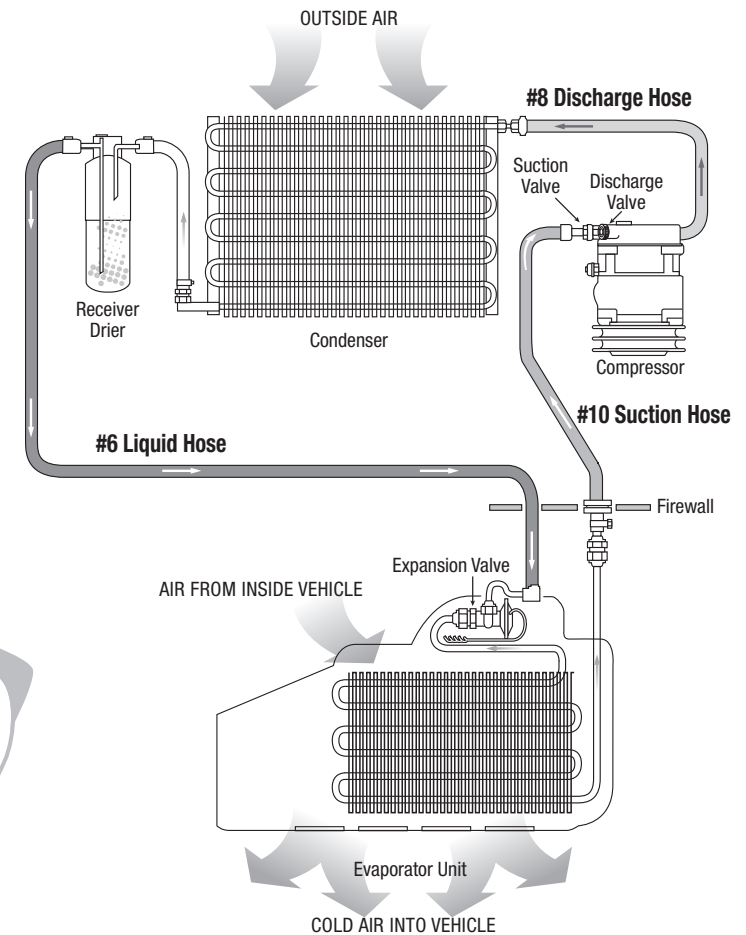
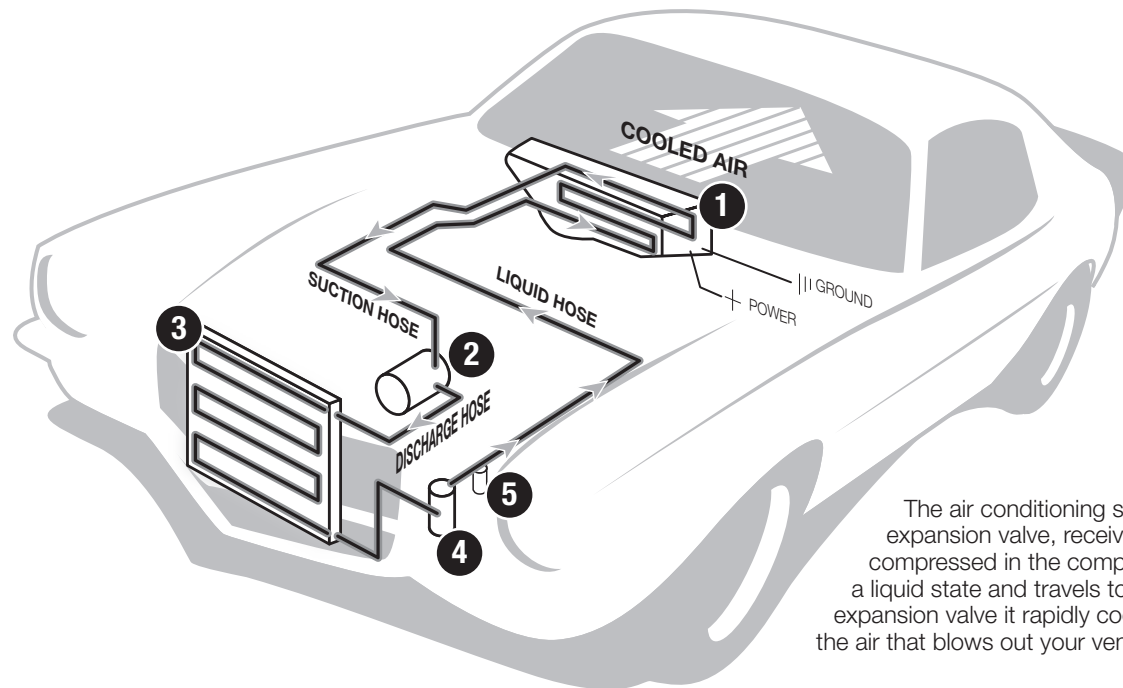

The air conditioning system in your car is comprised of a compressor, condenser, expansion valve, receiver/drier, and evaporator. Refrigerant (also known as Freon) is compressed in the compressor and turns into a gas. In the condenser, this gas is cooled to a liquid state and travels to the expansion valve. As the liquid refrigerant goes through the expansion valve it rapidly cools in the evaporator. A fan blows over the evaporator and cools the air that blows out your vents. The receiver-drier separates gas and liquid.

# CONTROL & OPERATING INSTRUCTIONS

Your new **Perfect Fit-Elite** system offers complete comfort capabilities in virtually every driving condition. This includes temperature control in all of the modes. This system also provides the ability to blend the air between Face, Heat, and Defrost modes simultaneously. To illustrate the various ways you can adjust the airflow direction and temperature - we've provided these handy illustrations and chart to show exactly how you can adjust your **Perfect Fit-Elite** for maximum comfort...

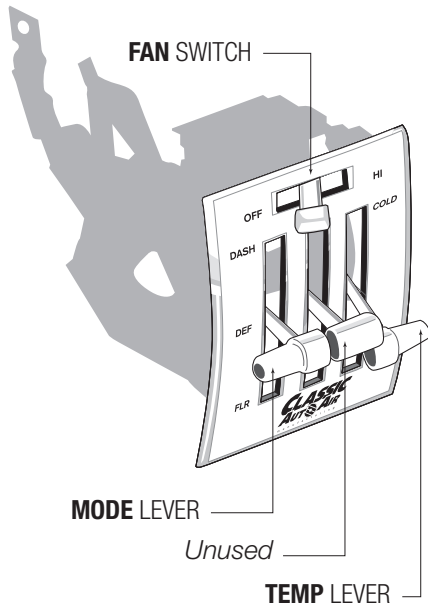

The FAN switch works like the OEM switch, the far left position is OFF (all power to the system is OFF in this position)

There are 11 levels of adjustment within the range of the DASH/FLOOR lever

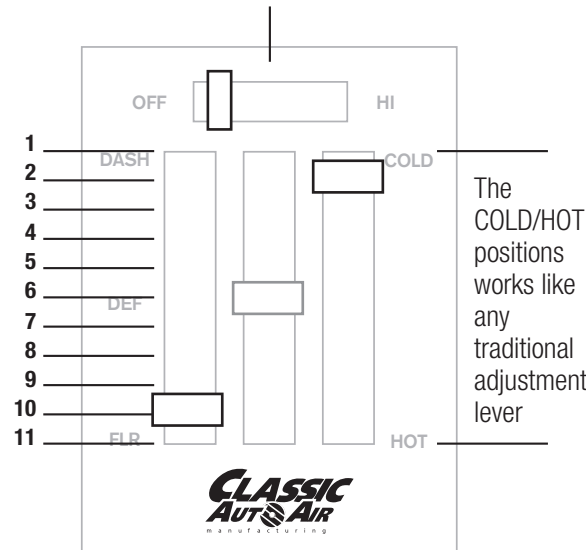

The COLD/HOT positions works like any traditional adjustment lever

**NOTE:** When the TEMP lever is in the "FULL COLD" position (TOP), the compressor is ON, no matter what position the DASH / FLR lever is in (think of it as a compressor-override function)

Left Lever Postion	Distribution	Compressor State
FACE	1 Face A/C 100%	<b>ON</b>
	2 Face A/C 80% Defrost 20%	
	3 Face A/C 60% Defrost 40%	
	4 Face A/C 40% Defrost 60%	
	5 Face A/C 20% Defrost 80%	
DEF	6 Defrost 100%	<b>ON</b>
	7 Floor 20% Defrost 80%	
	8 Floor 40% Defrost 60%	
	9 Floor 60% Defrost 40%	
	10 Floor 80% Defrost 20%	
FLOOR	11 Floor 100%	

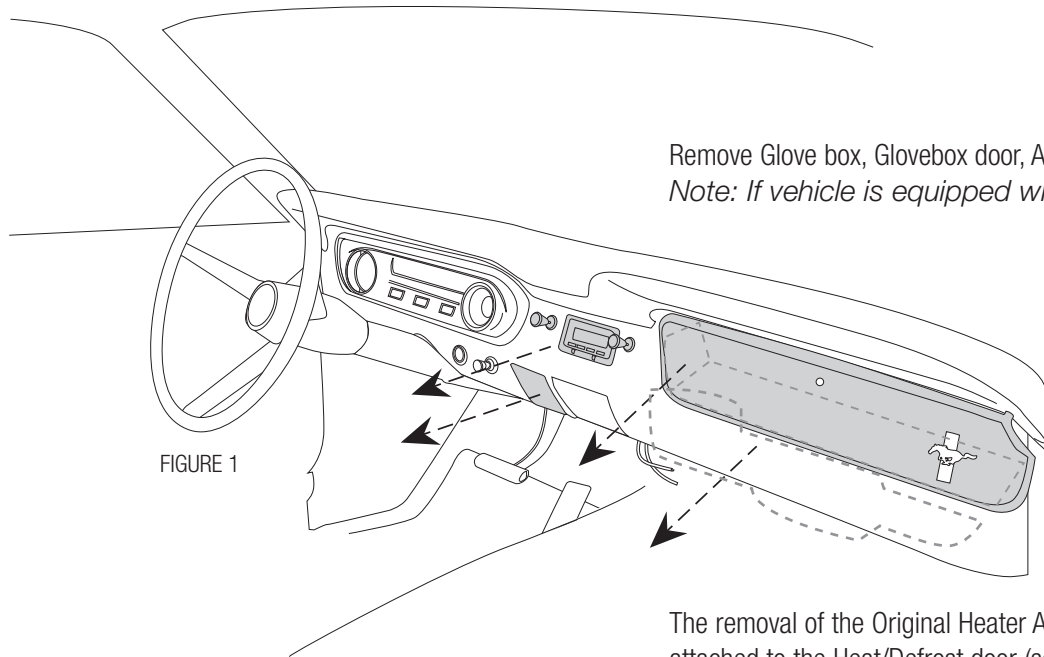

FIGURE 1

Remove Glove box, Glovebox door, Ashtray, and Radio, and set them aside for reinstall later (see figure 1).  
*Note: If vehicle is equipped with a console, remove entire console and set aside.*



When retaining parts it's a good idea to store parts in a zip lock bag, labeled with info where the parts came from and what size/type of tool is needed to reinstall. Cleaning the parts before you need to reinstall them is a good idea too.

The removal of the Original Heater Assembly can be accomplished by disconnecting three control cables. One is attached to the Heat/Defrost door (see figure 2). One is attached to the Temperature door, and one is attached to the Vent / Heat door (see figure 3). Disconnect the electrical harness from the assembly. Also remove attachment screw located in front of air inlet (see figure 4).

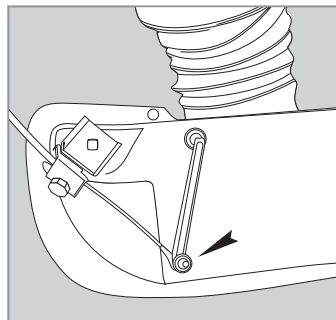

FIGURE 2

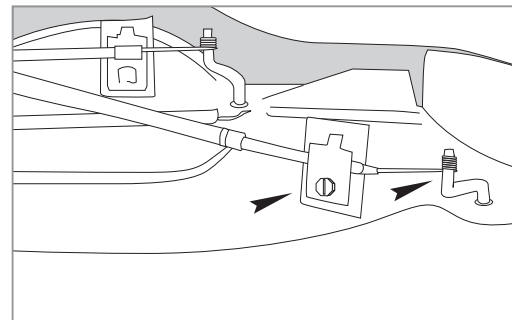

FIGURE 3

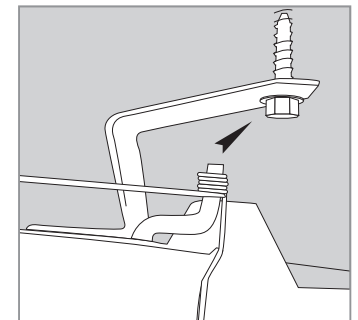

FIGURE 4

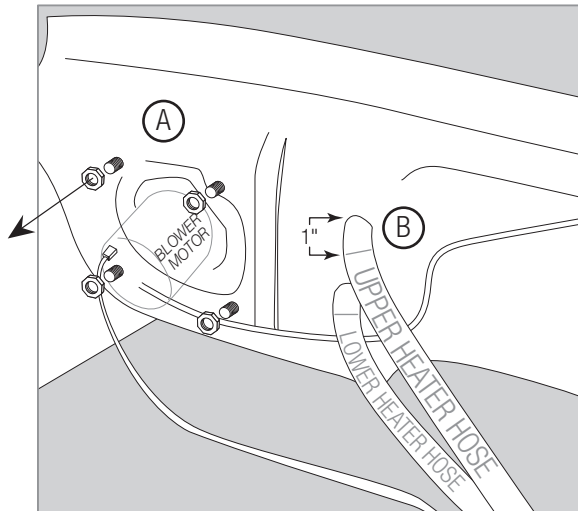

FIGURE 5

Locate blower motor on the firewall (**Passenger Side**) in the engine compartment. Remove all 4 nuts around blower. Also disconnect the electrical connector from the blower motor (see figure 5A). Cut wires at grommet in firewall.

**DRAIN COOLANT FROM RADIATOR. Store safely to reuse or recycle accordingly.** Cut heater hose approximately 1" from firewall (see figure 5B). Also, to prevent forgetting to refill the coolant when the installation is completed, do not put the cap back into place - instead put the cap to the side and cover radiator hole with a clean rag or something similar.

Located on top of instrument panel is the radio speaker cover plate, carefully remove the screws and **retain**. Under the cover there are two OEM defrost adaptors. Remove and discard adaptors and the defrost flex duct that is attached (see figure 7). Remove all heater assembly and defrost flex ducting. Discard (or save and pass along to a fellow Mustang enthusiast, if reusable).

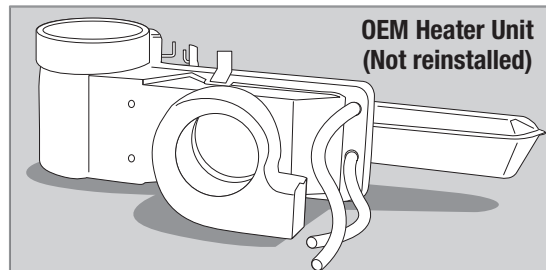

FIGURE 6

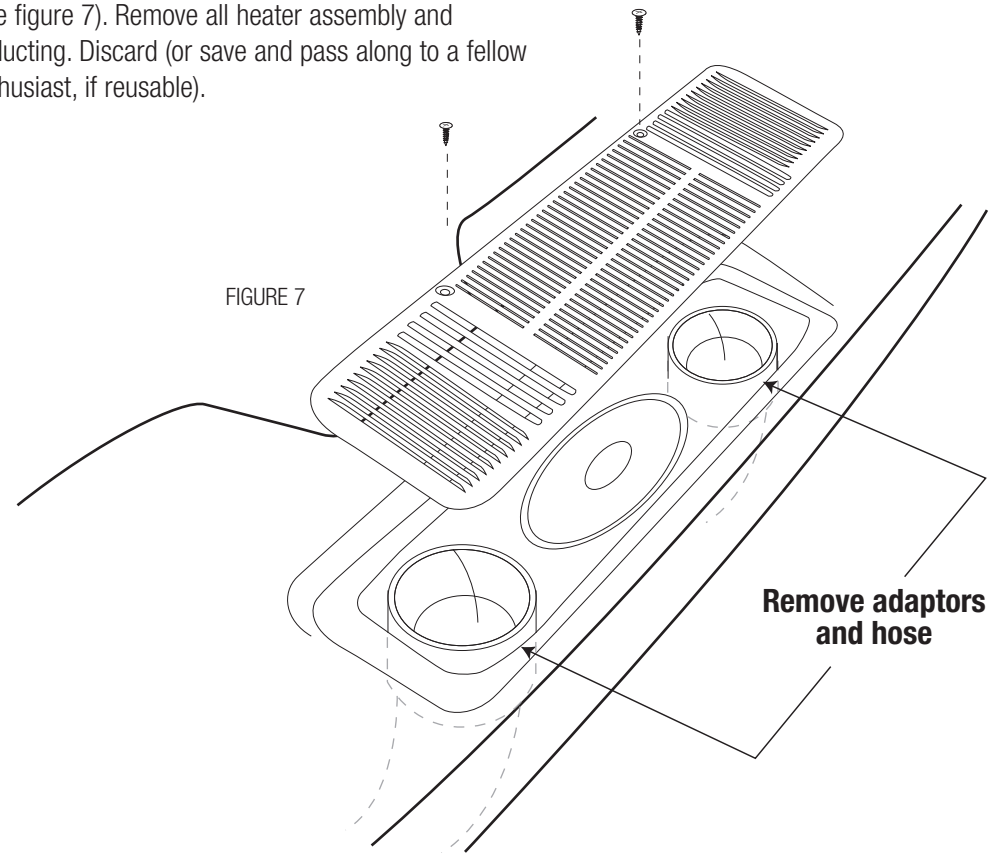
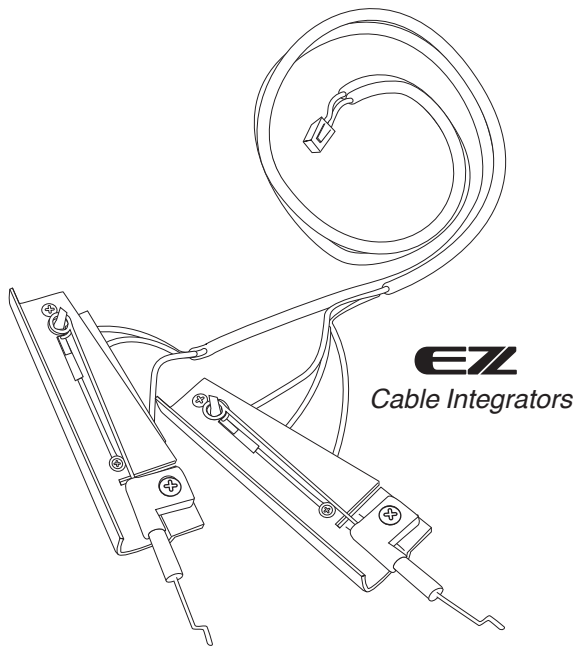

FIGURE 7

Remove adaptors  
and hose

# THESE ARE THE PARTS YOU WILL FIND IN BAG KIT A

You will use all of these parts and hardware during the next series of installation steps.



**EZ**  
Cable Integrators

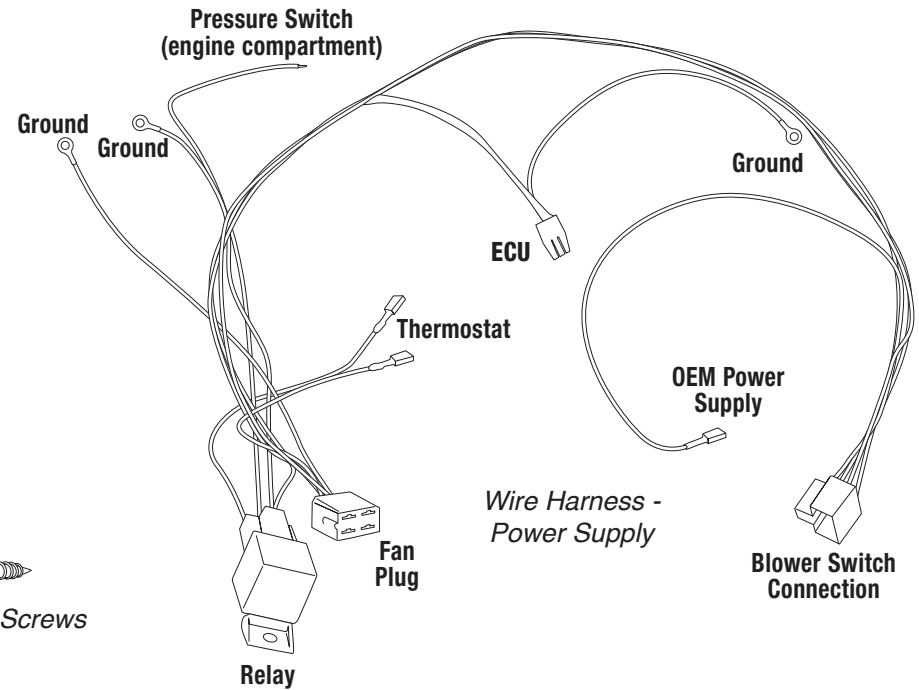

Two #8 - 20x3/8" Screws

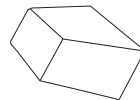

Blower Switch Knob  
PN# 525235

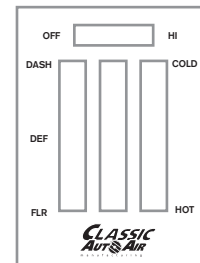

Face Plate Sticker  
0118-1

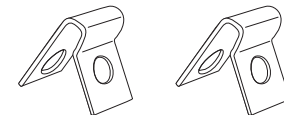

Two - Cable Clips  
PN# 25-1015



Three #6 - 20x3/8" Screws

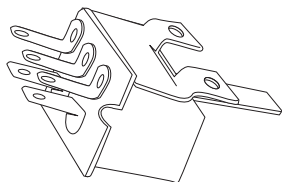

Blower Switch  
PN# 4M-235

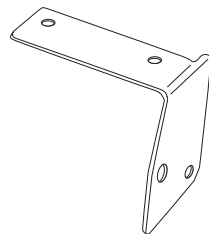

Blower Switch Bracket  
PN# 0023-8

Illustrations NOT shown actual size

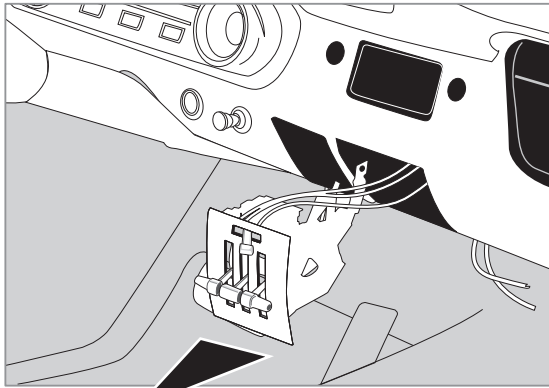

FIGURE 8

**REMOVE THE HEATER CONTROL HEAD FROM THE DASH.**

- 1) On the back side of the control head there are two nuts and retaining clips. Remove and retain. Remove the control head assembly (see figure 8).
- 2) Using an allen wrench, remove blower switch knob. Remove the control cables and the original blower switch and set aside (will not be reused).
- 3) Attach the blower switch bracket to the top part of the back of the face plate (see figure 9), utilizing the OEM screw (A) and the #6 - 20x3/8" screws we provided (B). So as not to interfere with the operation of the lever, install the lower screw from the inside to the outside (C). Then attach the NEW blower switch (D).

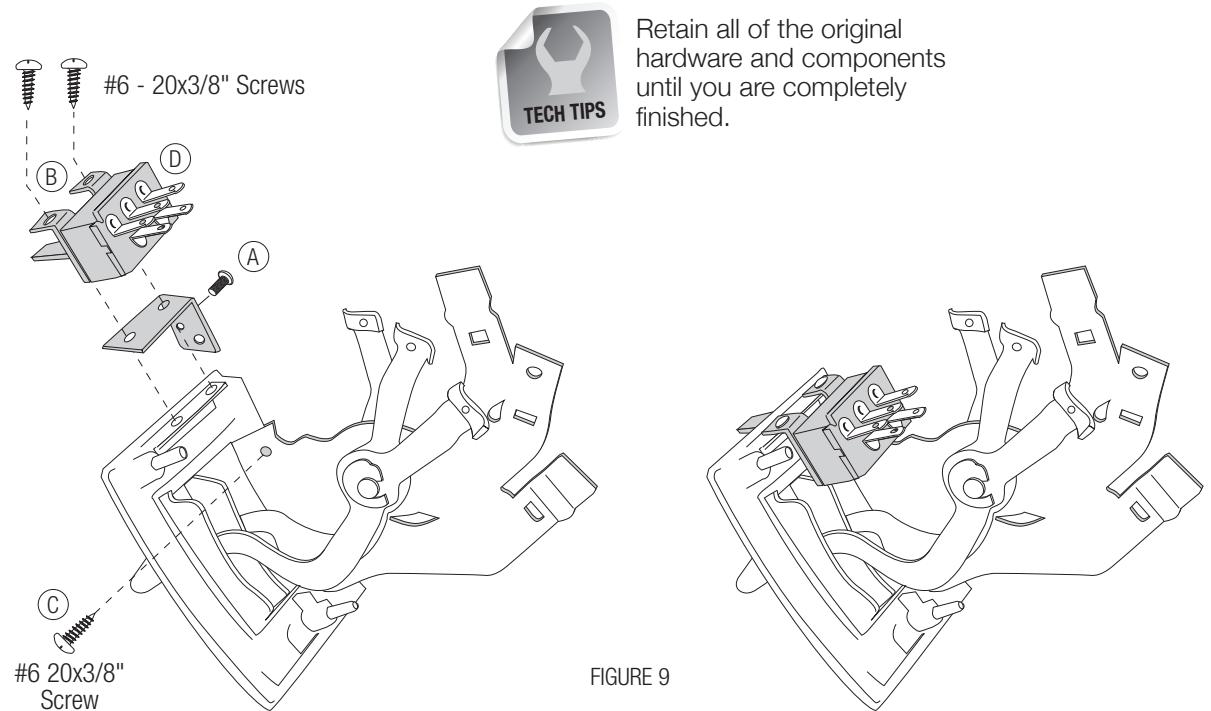
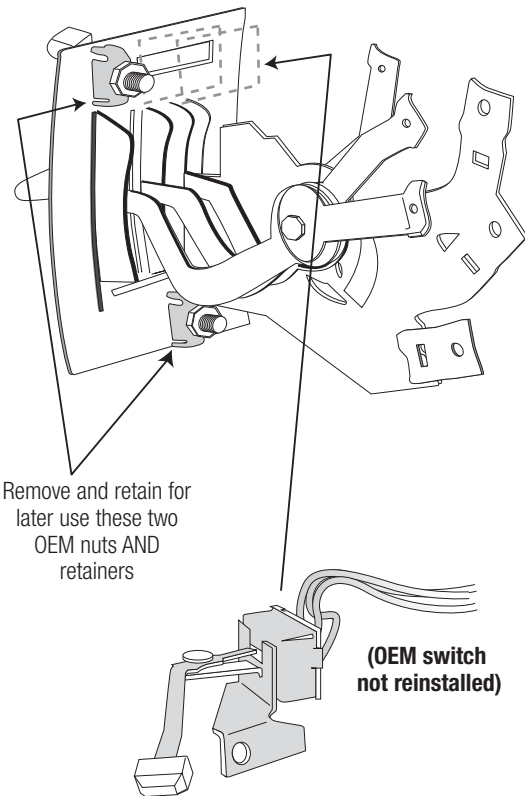
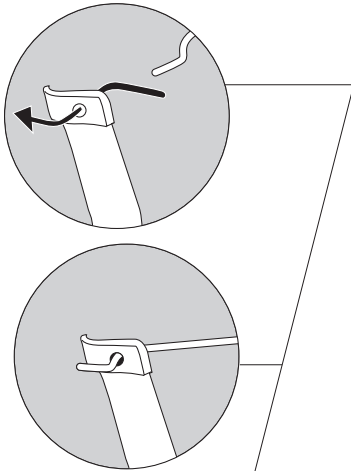
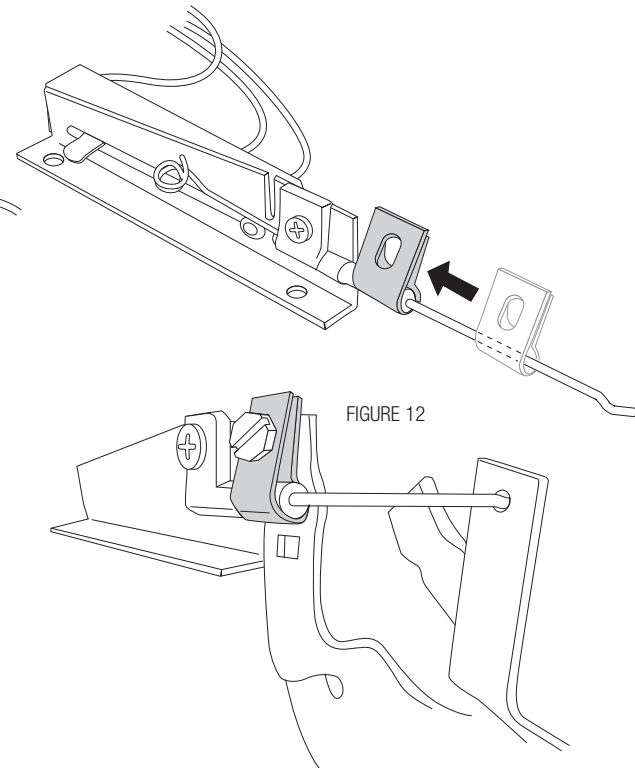
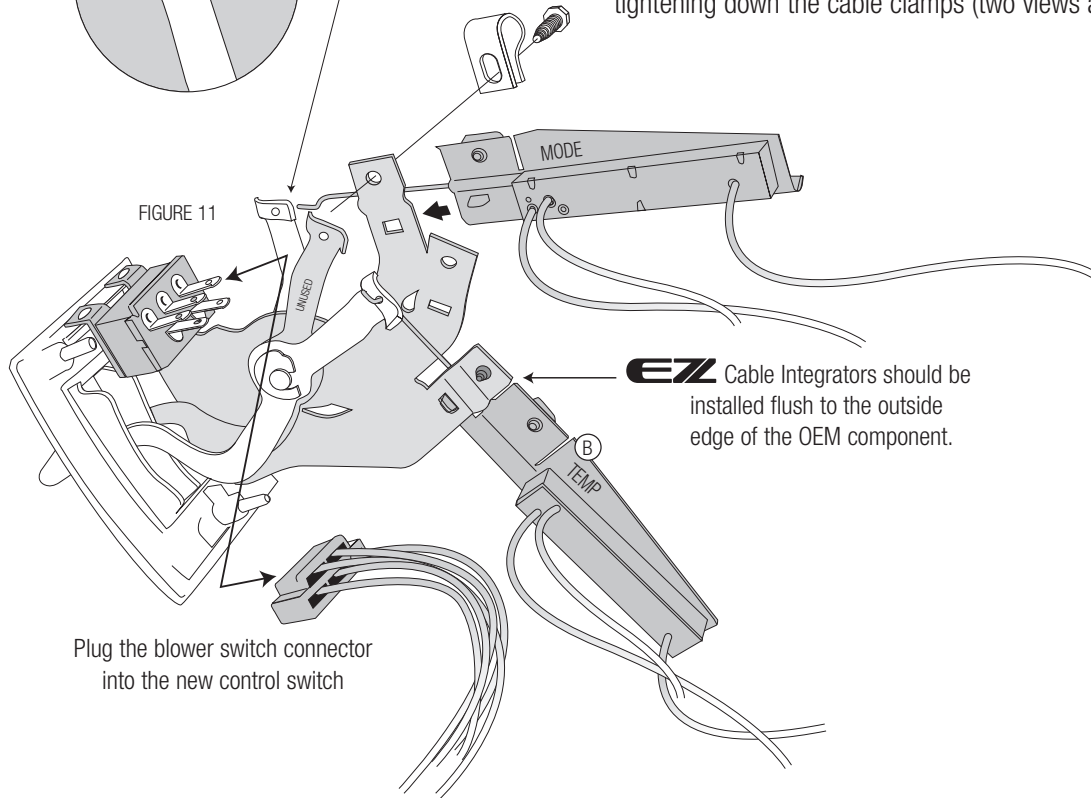

FIGURE 9



Within Bag Kit A we included our exclusive **EZ** Cable Integrators, which you will now attach to your OEM control head (as shown in Figure 12). Placing the control head on a flat work area, attach them exactly as shown with the integrator marked **"MODE"** (it has *Yellow, Blue, Green* wires) on the upper brace by attaching cable clip to cable integrators as shown in figure 12. Route the extended wire from the integrator thru the upper hole in the lever as shown, making sure it is flush with the OEM component. Repeat the same process for the other **EZ** Cable Integrator (B), it will be labeled **"TEMP"** (*Brown, Purple, and White* wires).

Attaching the cable integrators to the control head is accomplished by using the supplied cable clamps to secure the integrators to the levers (see figure 11). The first step is to insert the wire end of the integrators into the appropriate lever ends, then while making sure the integrators are flush to the edge of the control head, secure by tightening down the cable clamps (two views are shown in figure 12).



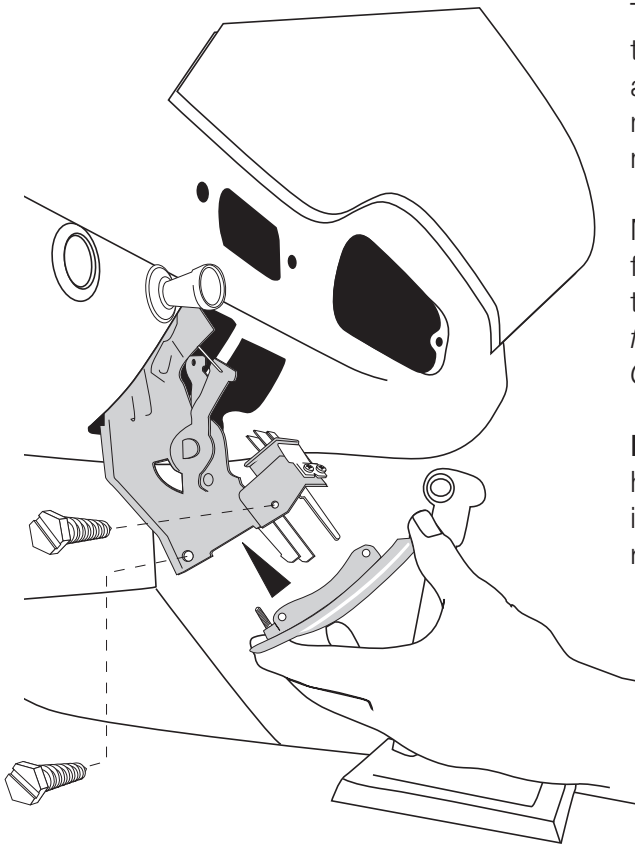
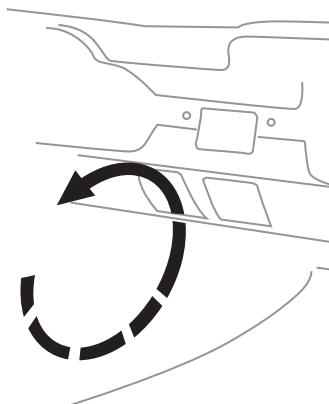

FIGURE 13



To insert the control head back into the dash you will need to perform a simple procedure first that will allow you to install from the inside dash outward. First remove all three knobs using an allenhead wrench, and remove the lower OEM screw holding the faceplate to the lever mechanisms. Then remove the face plate by removing the screw you installed earlier to hold the new blower switch.

Making sure the face plate surface is clean, oil and smudge-free, peel and apply the included faceplate sticker (optional). Apply using firm pressure from one side to the other. You can use this sticker to temporarily get accustomed the new controls, or leave it on (*we understand that for some vehicles our sticker may not be aesthetically pleasing, so this step is optional. Otherwise, just refer to control descriptions for operation procedures*).

**PLUG THE HARNESS BLOWER SWITCH CONNECTION** into the back of the control head and insert the entire harness and switch component back into the dash from the inside outward (see figure 13). With the control head coming thru the hole in the dash resecure the blower switch, bracket, and faceplate.

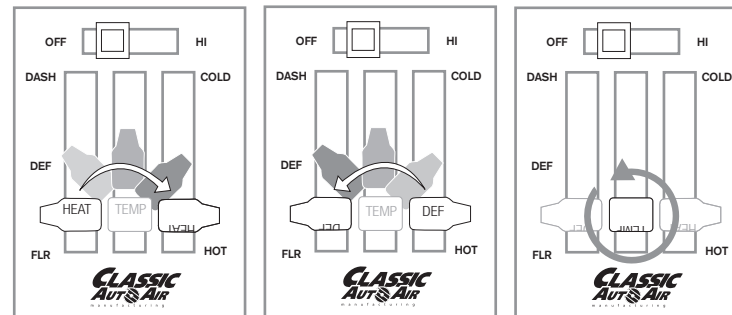

Position the entire control head back flush with the lower dash and secure with the OEM retainers and nuts you removed earlier.

Reinstalling the knobs is easy. However, the HEAT/DEF knobs will need to be rotated 180 degrees (upside down) and then reinstalled on the opposite side from where you removed them. The TEMP knob will also be rotated 180 degrees (but it's reinstalled in it's original position). Also install the new blower switch knob at this time. Because of the curved nature of the lower dash, you will not be able to see the indicator letters on the knobs (which are now upside down).

## THESE ARE THE PARTS YOU WILL FIND IN BAG KIT B

You will use all of these parts and hardware during the next series of installation steps.



Evap Support Bracket  
PN# 0023-7

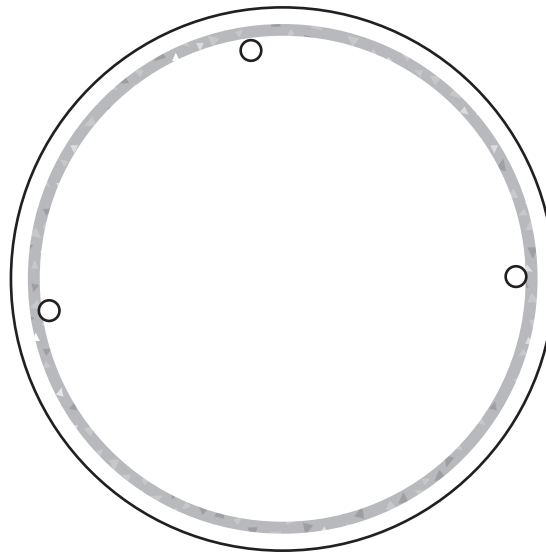

Fresh Air Inlet Block Off  
PN# 10-1025-2

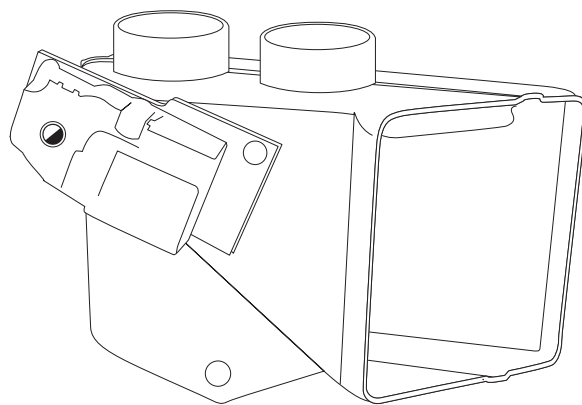

Defrost/Heat Duct Assembly  
PN# 2-2025-2

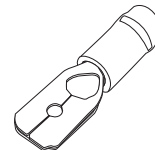

One Male Spade Connector



One J-Clip



Two 1/4 - #20 x 5/8" Bolts

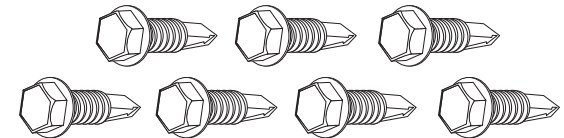

Seven #10 - 16 x 3/4" Tek Screws



Four #10 - 10 x 5/8" Phillips Screws



One 1/2" Washer

Illustrations NOT shown actual size

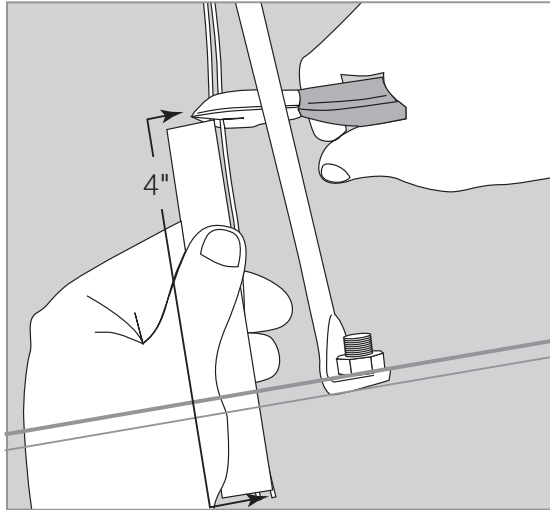

FIGURE 16

Locate the original wiring harness that supplied power to the original heater motor (these wires were previously cut on the engine side of the firewall). Reaching thru the glove box opening pull these wires out of their grommet. Measure 4" from harness and cut both wires (see figure 16). On the OEM power supply wire attach a 1/4" insulated male spade connector. **Within the OEM fuse box upgrade the factory HEATER fuse with a 20 amp fuse (VERY IMPORTANT).**

Locate the bottom left mounting hole in the firewall that attached the original heater motor. From **inside** of the vehicle drill a 5/8" dia. hole for the drain tube. **TEMPLATE NOTIFICATION!** A handy drilling template is included in this manual (example shown in figure 17).

**CAUTION:** On the engine side of the firewall there is a brake line. Be careful not to drill through the brake line. It may be necessary to carefully push this line out of the way, securing it a bit lower is usually all that is necessary (see figure 18)

**All preliminary modifications to the vehicle are complete.**

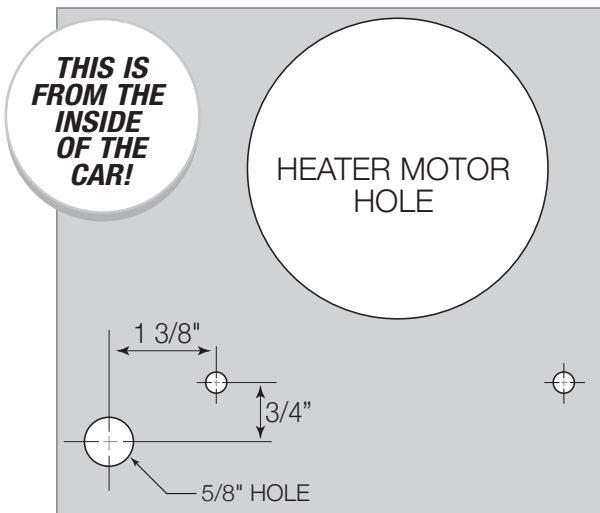

FIGURE 17

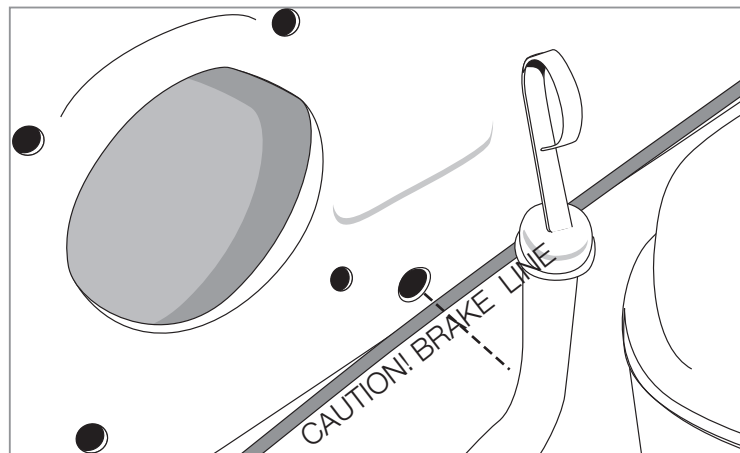

FIGURE 18



**YOU CAN DRILL A SMALL PILOT HOLE IN**

**THIS LOCATION FIRST WITH A SMALLER DRILL BIT (LIKE A 9/32"), THEN PROCEED WITH THE 5/8" BIT ONCE YOU KNOW YOU HAVE CLEAR SPACE.**

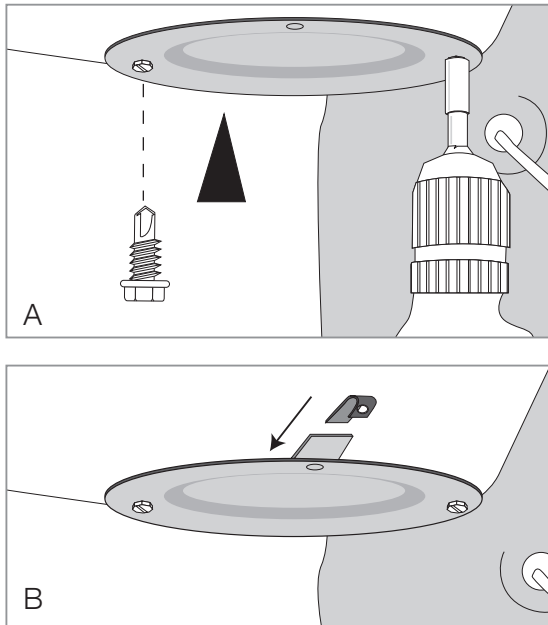

FIGURE 19

Locate the fresh Air inlet block off. Install over hole in inlet cowl as shown (see figure 19A). Attach with three #10 - 16 x 3/4" Tek Screws.

Locate the mounting tab location as shown and attach the 1/4" 20 J-clip supplied (see figure 19B).

Remove evaporator unit from box and place on a clean work bench.

Locate defrost / heat duct assembly and attach to the evaporator using two #10 - 10 x 5/8" Phillips screws (see figure 20). **NOTE: Be sure that the s-clips are pushed over rear flange on evaporator.**

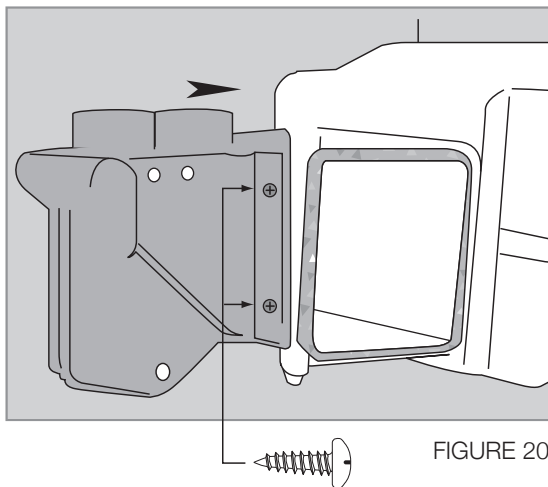
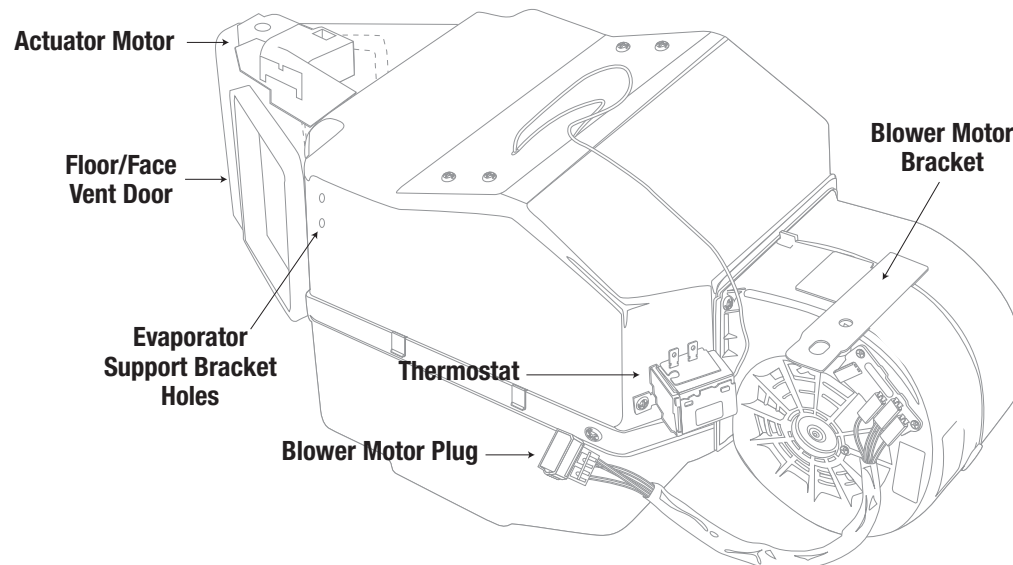

FIGURE 20

*Take a minute to familiarize yourself with the evaporator unit:*



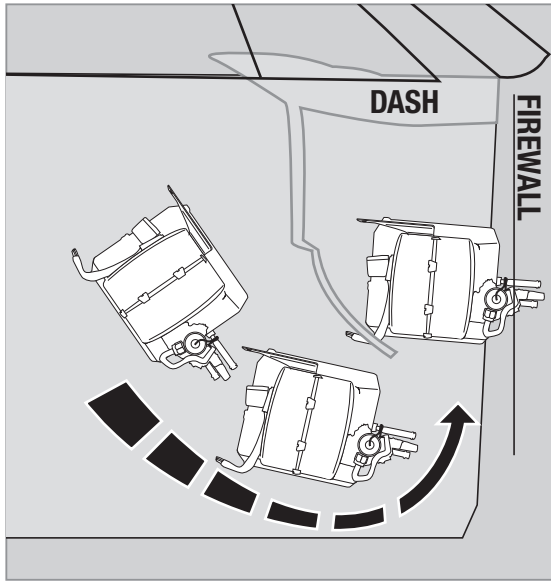

FIGURE 21

Installing the complete evaporator unit under the dash will go much easier with the help of a friend. One person can take the unit within the car and “roll” up and under the dash while the other person can be ready at the firewall area with one of the 1/4" - #20 x 5/8" bolts to secure the unit in place (see figure 21). **Now the unit will be easy to level and secure. Leveling the unit is very important to insure proper drainage of condensation.**

On back side of the evaporator is a mounting bracket with a 1/4"-20 J-clip. This bracket will go flush with the inside firewall and you will secure the evaporator by inserting one 1/4" - #20 x 5/8" bolt with a 1/4" washer (from the engine side) using the bottom right hole (that originally attached the original heater assembly, see figure 22).

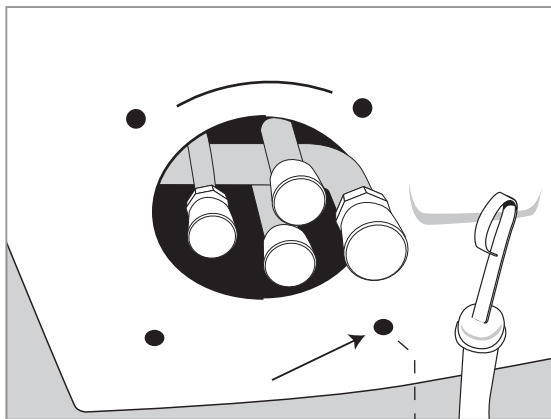
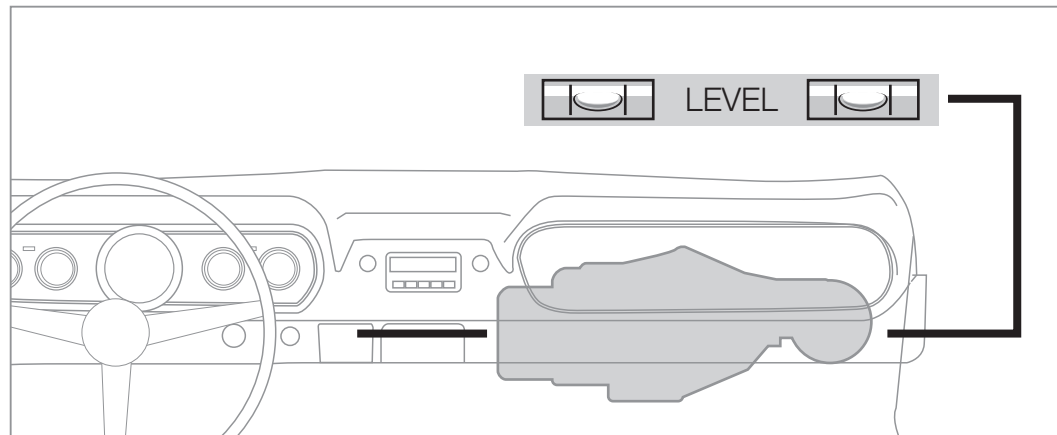
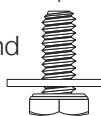

FIGURE 22

1/4 - #20 x 5/8" bolts and a 1/4" washer



Be sure to align the evaporator unit level with the bottom of instrument panel (assuming the vehicle is sitting level) as shown above, but with a small degree of tilt toward the back to allow proper drain of condensation.

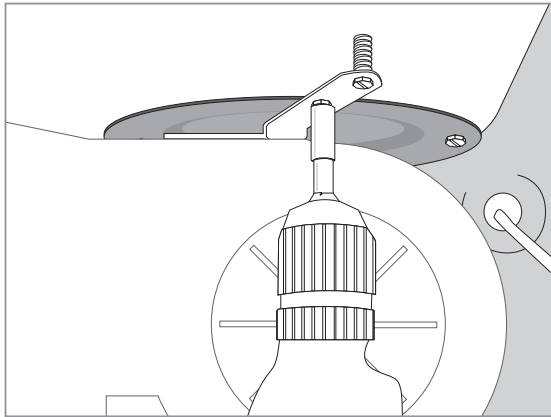

FIGURE 23

The second 1/4 - #20 x 5/8" bolt attaches the blower motor mounting bracket in the same location as the original heater mounting in front of the Air Inlet. The blower support bracket will have an additional hole behind the 1/4 - #20 x 5/8" Bolts. Install a #10 - 16 x 3/4" Tek screw through this hole and into the cowling (see figure 23).

Locate the **UPPER MOUNTING BRACKET** and attach to evaporator unit using two #10 - 10 x 5/8" Phillips screws. Attach other end to the cowling. Attach with #10 - 16 x 3/4" Tek Screws supplied (see figure 24). **IMPORTANT NOTE:** On the side of the main unit you will see several holes for mounting holes... **ONLY USE THE ONES ON THE FAR LEFT FOR THIS BRACKET!** Do not tap into the other holes for any reason (see Figure 25). Also, use a screwdriver and hand-power and do not over-tighten so you don't strip the holes.

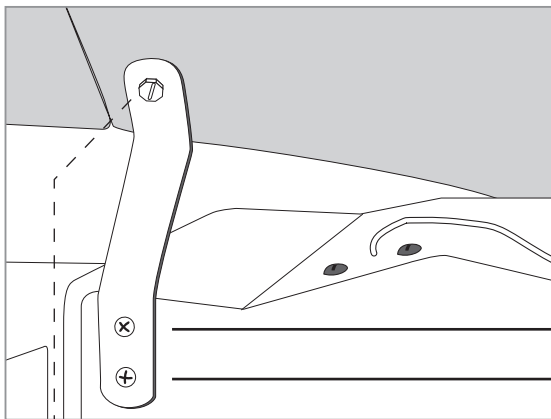
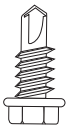

FIGURE 24



#10 - 16 x 3/4" Tek Screw

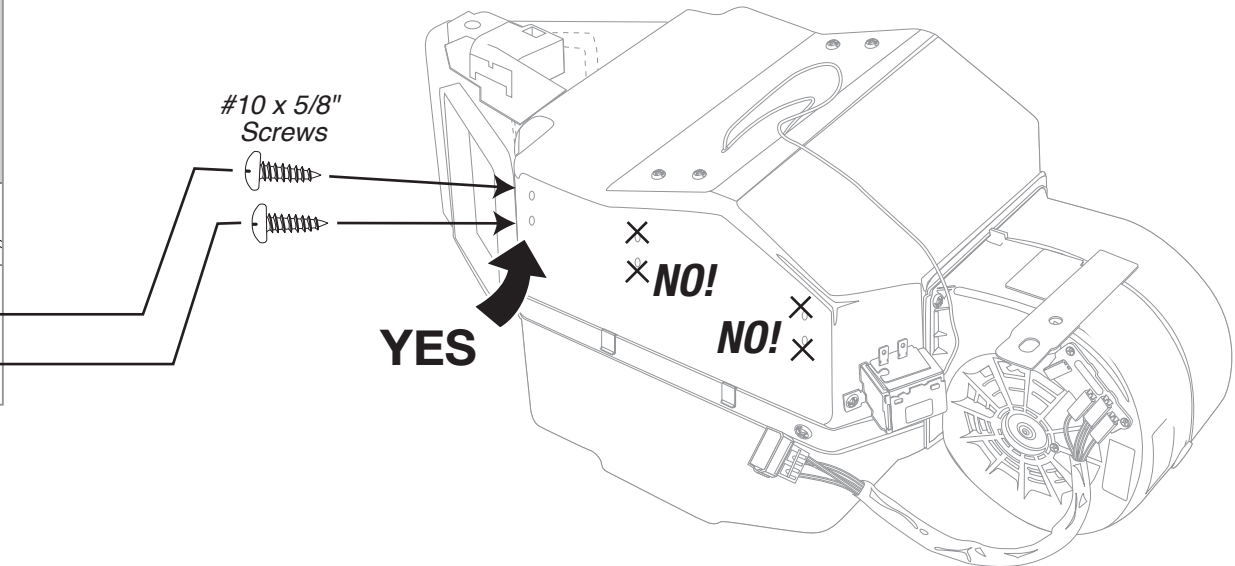
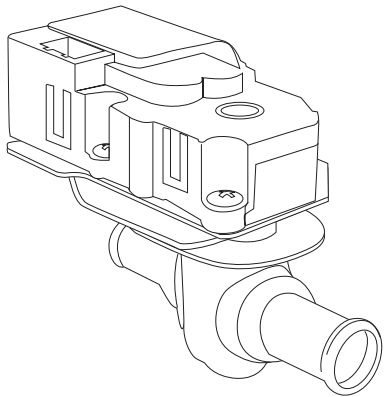

FIGURE 25

## THESE ARE THE PARTS YOU WILL FIND IN BAG KIT C

You will use all of these parts and hardware during the next series of installation steps.



*Electronic Water Control Valve  
PN# 16-1081-2*

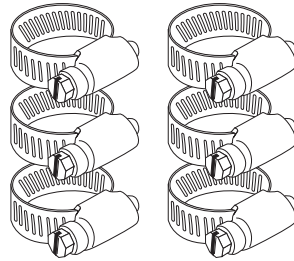

*Six Worm Gear Clamps*



*Clear Plastic Drain Tube*

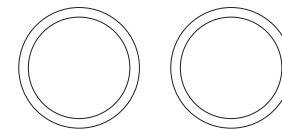

*Two 1" Cap Plugs*

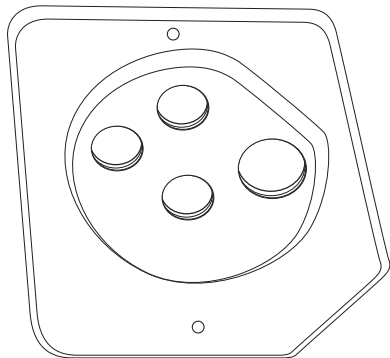

*Firewall Block Off  
PN# 10-1025-1*

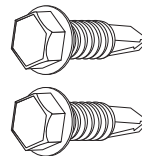

*Two #10 - 16 x 3/4" Tek Screws*



*Refrigerant Tape*

Illustrations NOT shown actual size

Water valve hose connects to this connection

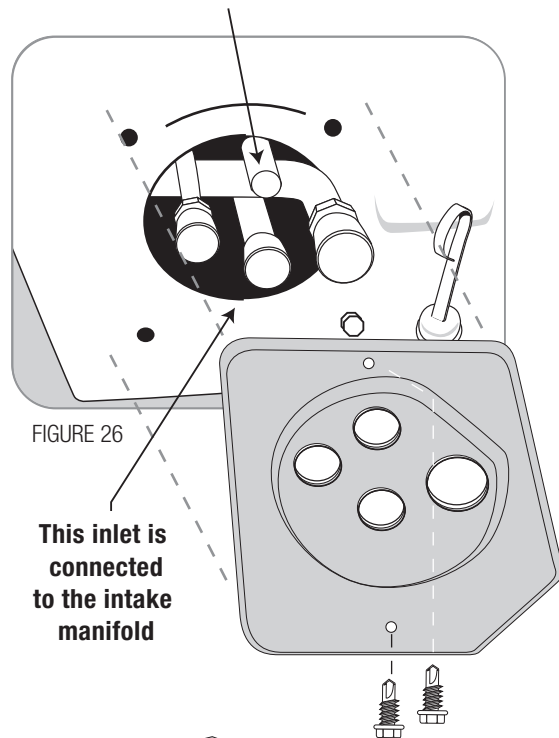
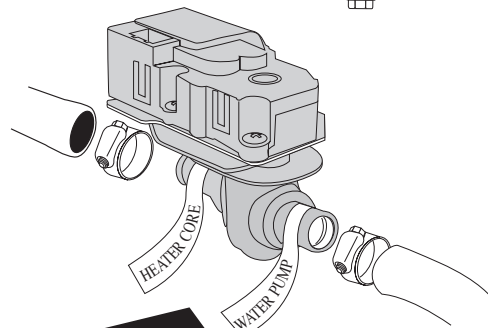

FIGURE 26

This inlet is connected to the intake manifold



FOLLOW THESE TAGS... CHECK IT TWICE BEFORE PROCEEDING!

In **Bag Kit C** you'll find the firewall block off. Install this over the hose connections coming thru the firewall within the engine compartment. Attach with six #10 - 16 x 3/4" Tek screws. **TIP: This would be a good time to "jump" ahead a bit, and remove the ORANGE cable from Bag Kit D and route it thru the block off plate (it will be plugged into the electronic water valve). The cable for the electronic water valve can share the hole with smaller liquid line opening.**

**IMPORTANT NOTICE: PROPER INSTALLATION OF WATER VALVE INSTRUCTIONS!!!**

Classic Auto Air has done extensive testing on the correct method to install the water valve in order to get a repeatable and progressive temperature control. **Your water valve MUST be installed per these instructions!... (if not, your system will not work properly... and that's an absolute fact).**

The **lower** connection on the tubes coming thru the block off assembly is going to be routed to the water outlet on the intake manifold. Attach your hose with cable clamps on both ends and route where it will not interfere with linkage or come in contact with exhaust manifolds or headers.

The **upper** port coming thru the firewall will be routed to and thru your new your electronic water valve (the water valve is marked for easy installation). First Attach a 6" piece of 5/8" dia. heater hose with the supplied worm gear clamp. Attach to the inlet side of the water valve using another supplied hose clamp. Attach a heater hose from the outlet side of the electronic water valve and route to the connection on the water pump.

Insert a 6" piece of the clear, 1/2" drain tube we included through the hole previously drilled and attach over the drain nipple. Seal around tube with refrigerant tape.



## THESE ARE THE PARTS YOU WILL FIND IN BAG KIT D

You will use all of these parts and hardware during the next series of installation steps.

The ECU will be in it's own box, within this bag kit.

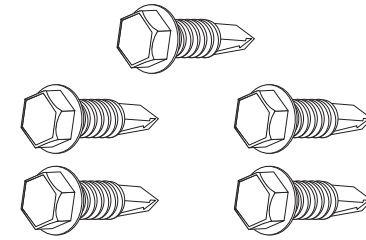
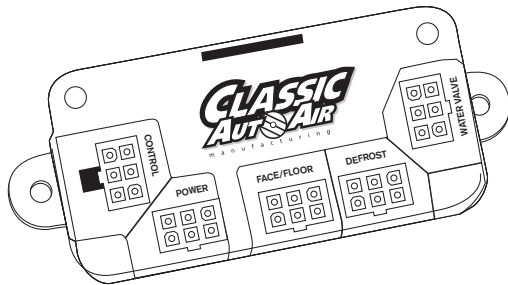

Five #10 - 16 x 3/4" Tek Screws

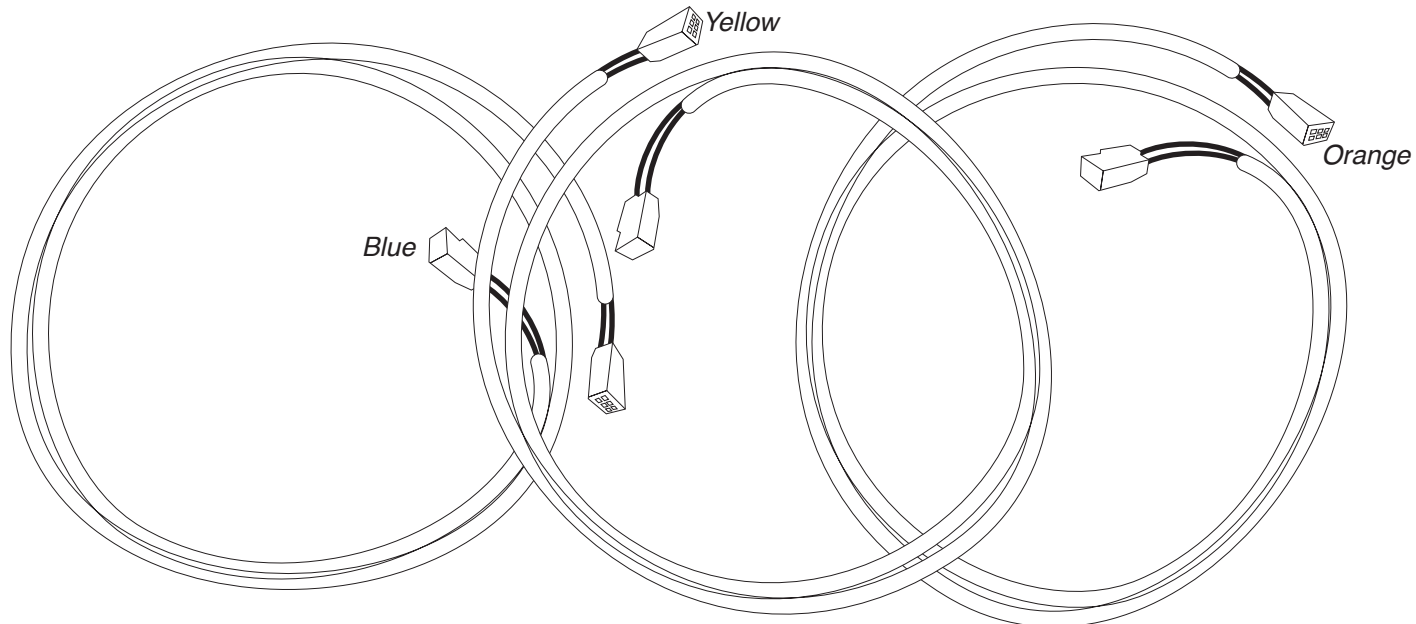

**EZ** Wire Harness System

Illustrations NOT shown actual size

# Wiring Diagram/Overview

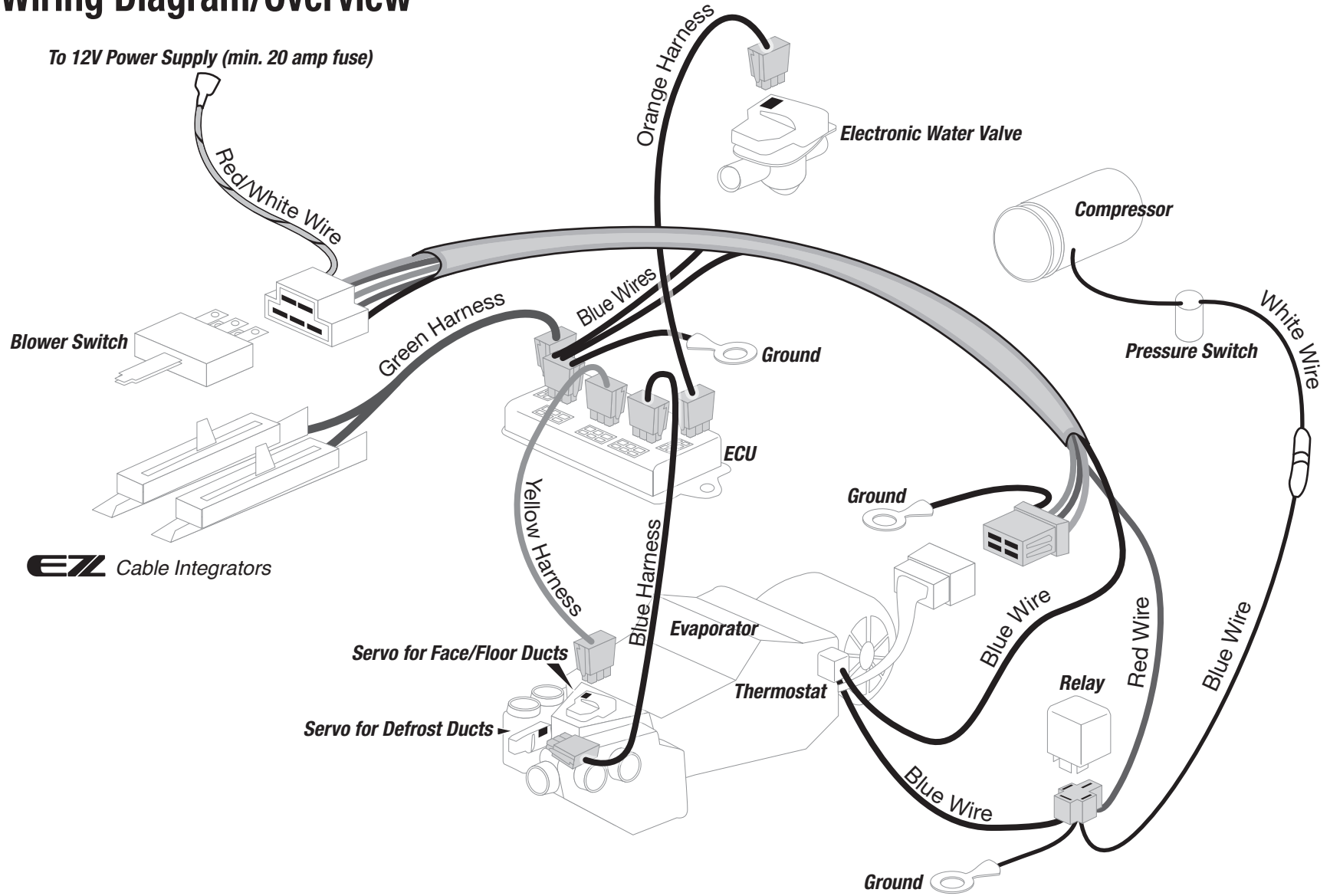

**EZ** Cable Integrators

**REMINDER: BE SURE THAT THE WIRING HARNESS DOES NOT INTERFERE WITH THE OPERATION OF ANY CONTROLS.**

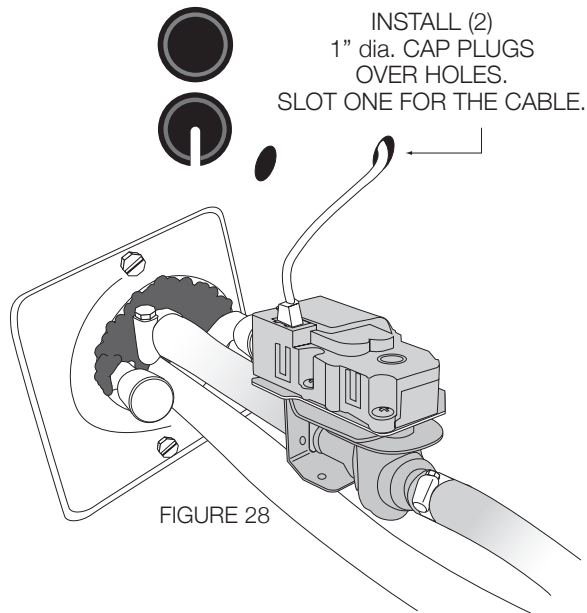
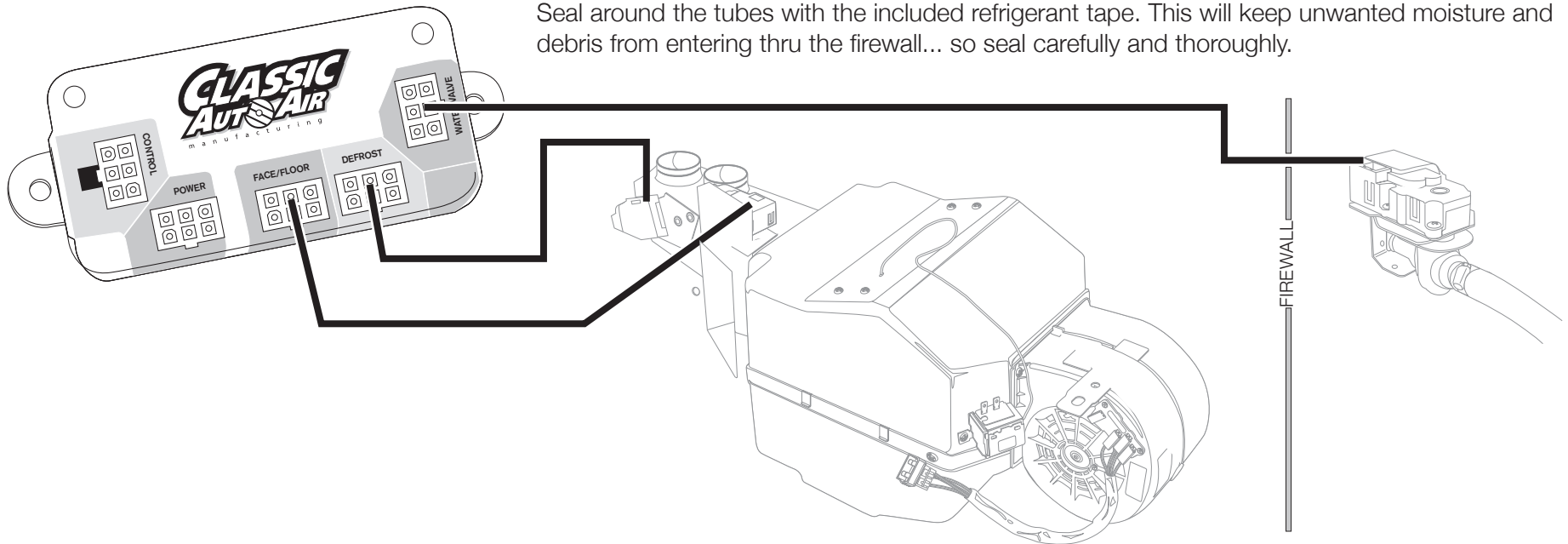

FIGURE 28

We've included enough extra cable length to allow you to mount the ECU in a variety of places. It is very important that you mount this in a place where it will stay dry and that vibration is at a minimum. Also make sure that where ever you mount it it does not interfere with any moving controls or cables. We recommend mounting it just above the right hand side of the main unit using the included tek-screws. **IMPORTANT! DON'T MOUNT THE ECU PERMANENTLY JUST YET. THAT CAN BE DONE AFTER YOU CALIBRATE THE UNIT (SEE NEXT PAGE).**

In Bag Kit D you will find three wiring harnesses with connections at each end. Plug the harness with YELLOW band into the YELLOW ECU port and the other end into the servo motor on the main unit (motor is marked with YELLOW INDICATOR). Repeat this process for the other two harnesses, following the color coding indicated on cables and ports. Attach cable in the engine compartment to the electronic water valve (see figure 28). Using one of the CAP PLUGS provided, slot it and install over the heater hose/cable. **NOTE:** The GREEN harness connection will be made from the harness you previously installed, just plug the loose connection in the CONTROL port on the ECU.

Seal around the tubes with the included refrigerant tape. This will keep unwanted moisture and debris from entering thru the firewall... so seal carefully and thoroughly.





Temporarily reconnect the car battery at this time. You will need a full 12 volts to complete the calibration.

## WELCOME TO EZ CALIBRATION...

Follow these directions carefully and your unit will be calibrated in just a few minutes.

Before we boxed and shipped your unit, we tested and calibrated it to factory specifications to make sure it is capable of operating at maximum efficiency. However, the unit must still be calibrated to your specific vehicle and controls. This is an easy process that can be done in a few steps. If for any reason your unit does not calibrate properly the first time, just turn off the unit and rerun the setup process. **NOTE: When you move a knob to a new position, do it in ONE continuous motion.**

**#1**

Plug CALIBRATION KEY into ECU

**#2**

Position your controls like this example.

**#3**

Move FAN control to medium in one motion...

LED ON 1 Second Later... LED OFF

**#4**

Move MODE control to DASH in one motion...

LED ON 1 Second Later... LED OFF

**#5**

Move TEMP control to HOT in one motion...

LED ON 1 Second Later... LED OFF

**#6**

After 1 second the LED turns back ON

You may be able to hear the internal door(s) move back and forth...

LED ON Approx. 30 Seconds Later... LED OFF

**#7**

Move the FAN knob to OFF (powers off unit)

**#8**

**REMOVE KEY AND STORE IN SAFE PLACE**

**That's it. Your unit is now fully calibrated. Disconnect the battery and move on to the next phase....**

# THESE ARE THE PARTS YOU WILL FIND IN BAG KITS E, F, and G

You will use all of these parts and hardware during the next series of installation steps.

## Bag E

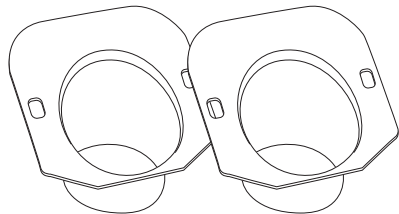

Defrost Adaptor Defusers  
PN# C5ZZ18490-A

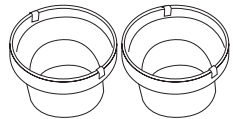

Defrost Adaptor Reducers  
PN# 2-1025-3

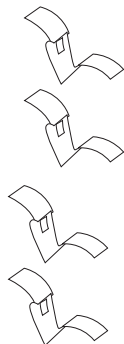

Four V Clips

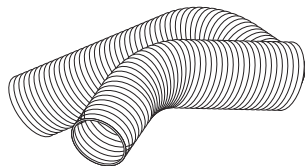

Two Duct Hoses, 2" I.D.



Four Zip-Ties

## Bag F

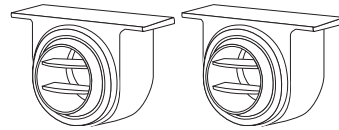

Two Louver Ball Assemblies  
PN# 2-1005

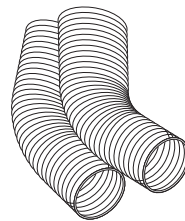

Two Duct Hoses, 2" I.D.

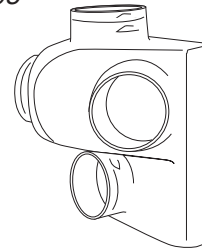

Face Duct Assembly  
PN# 2-2025-1

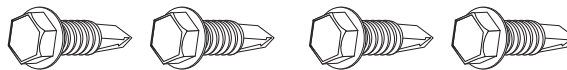

Four #10 - 16 x 3/4" Tek Screws



Four Zip-Ties

## Bag G

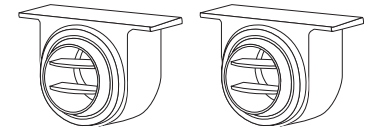

Two Louver Ball Assemblies  
PN# 2-1005

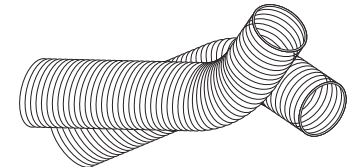

Two Duct Hoses, 2" I.D.

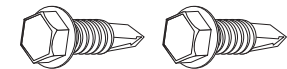

Four #10 - 16 x 3/4" Tek Screws

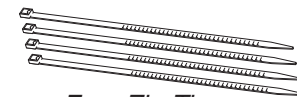

Four Zip-Ties

Illustrations NOT shown actual size

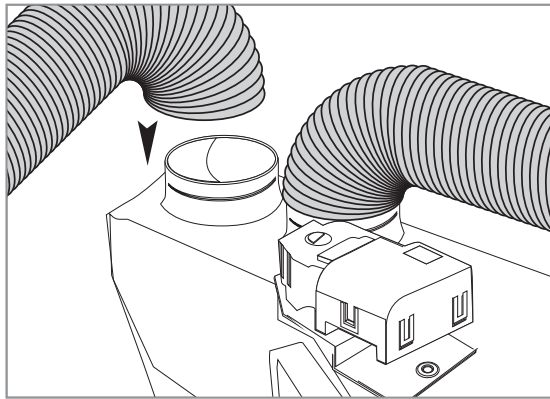

FIGURE 29

**The following steps are for left and right Defrost Diffusers:** Locate and route the duct hoses from the defrost/heat duct assembly (see figure 29) upward toward the defrost adaptor defusers. Next locate and install defrost adaptor defusers from the top of the dash and secure with v-clips supplied. Attach flex hose to the defrost defuser adaptors using zip-ties. Push adaptors onto defusers from below. The other end of the duct hose is installed over the defrost/heat duct assembly outlets on main unit (see figure 30 and the diagram below).

Reinstall radio speaker cover plate over the defrost defusers using the original screws.

The face duct assembly comes preinstalled with s-clips which allow you to install onto the evaporator unit quickly and securely (see figure 31).

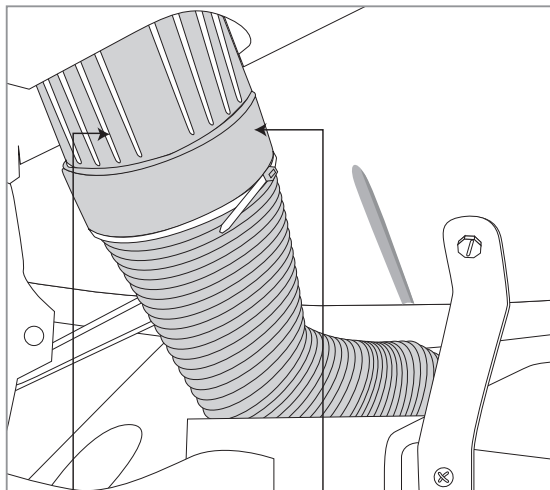

FIGURE 30

Defrost Adaptor Defuser

Defrost Adaptor Reducer

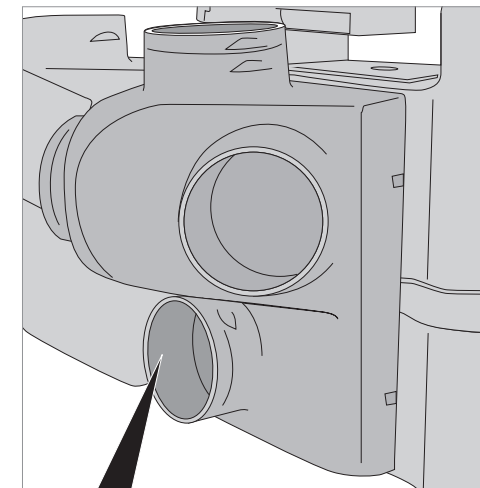
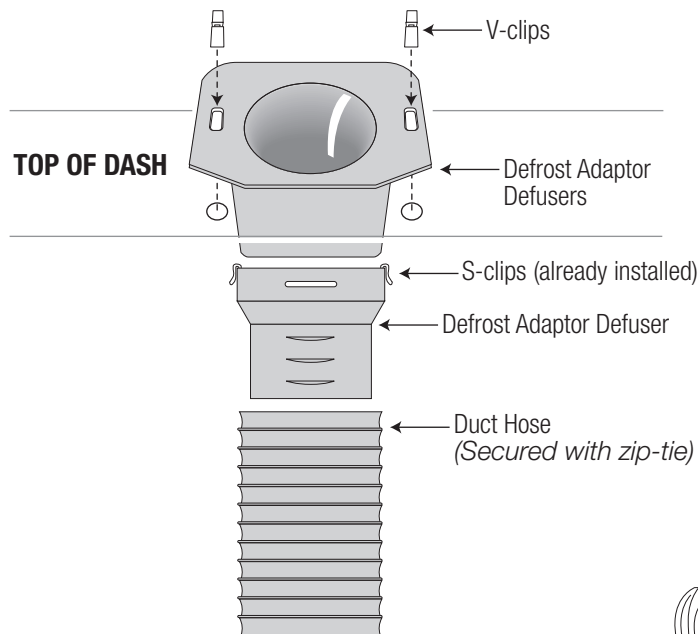
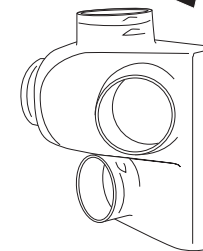

FIGURE 31



**Bag Kit F:** Attach a louver ball assembly to the bottom edge of instrument panel as shown below. Use two #10 - 16 x 3/4" Tek screws through top of the louver ball assembly.

Route supplied flex hoses as shown below. Take your time and route them so they don't become kinked or torn. The smoother the route the better the airflow.

Attach a louver ball assembly to the passenger side using two #10 - 16 x 3/4" Tek screws.

**Bag Kit G:** Repeat the previous attachment instructions for the center louver ball assemblies. Mount these where you feel you'll get the most benefit from the airflow.

Attach duct hose to left face duct assembly outlet. This will then be routed down to the louvers as shown. The duct hose will be routed from the remaining face/floor assembly outlet over the defrost duct hose and across to the passenger side louver ball assembly.



During installation of the hoses be aware of the eventual movement of the wiper arm components. Also, the smoother the route of the flex hoses the better the airflow.

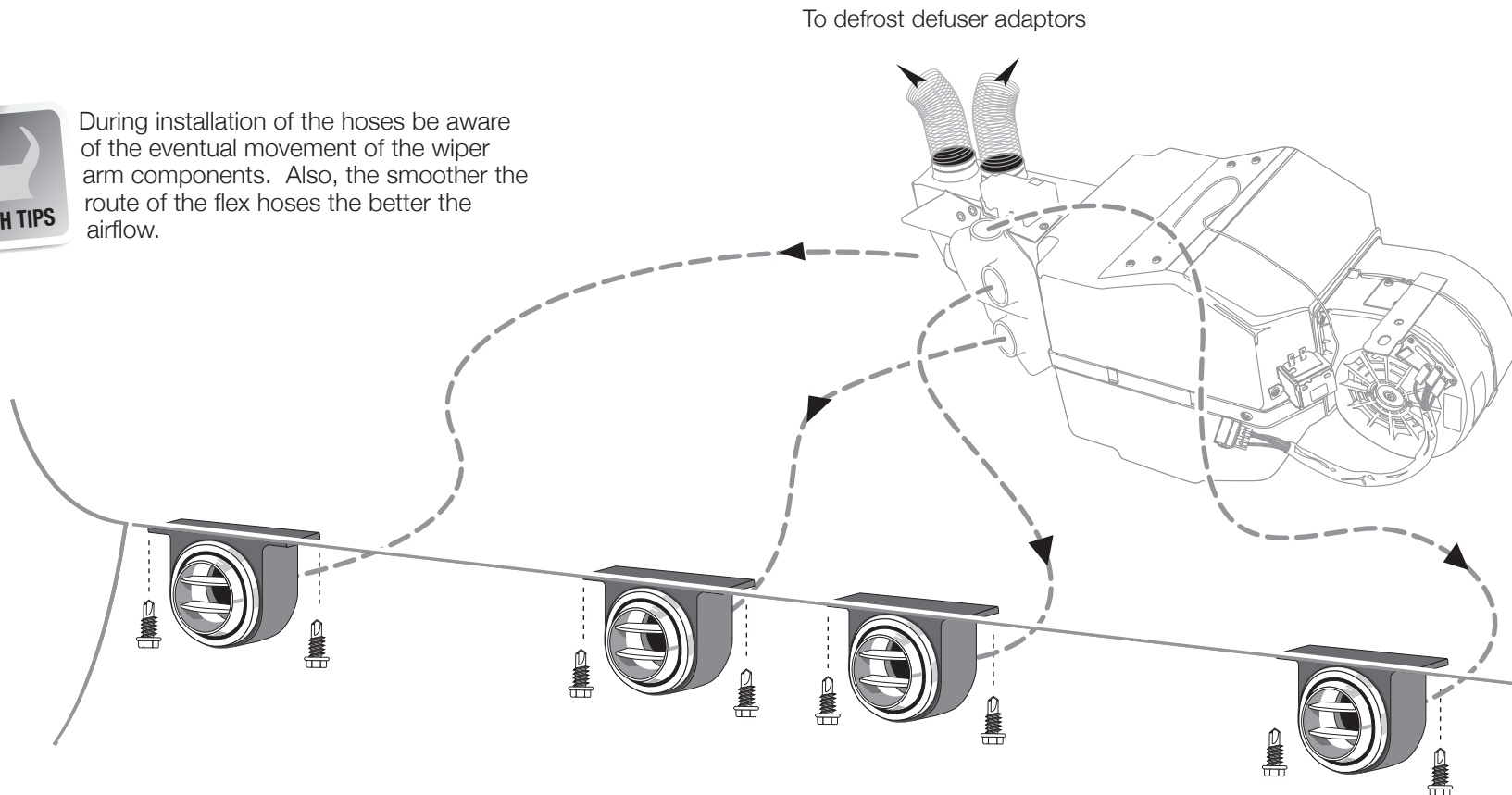

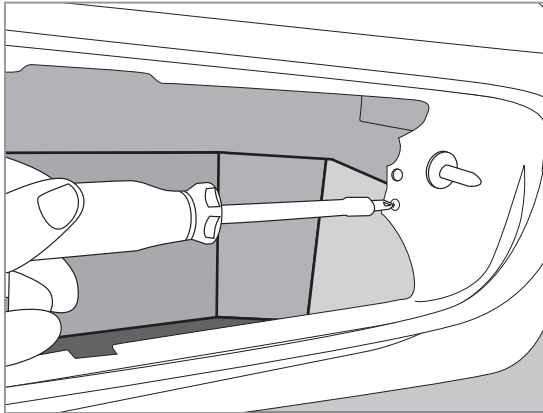

FIGURE 32

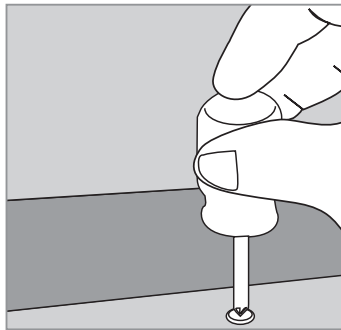
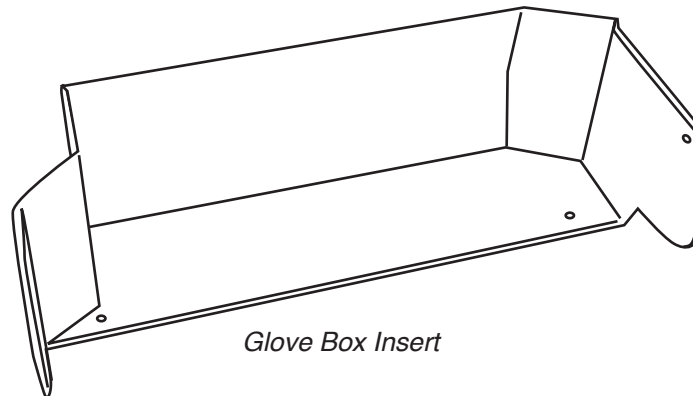

FIGURE 33

Locate the new glove box provided in kit. Install using original hardware (see figure 32-33).

**Caution:** Carefully check under the Instrument Panel for all cables, electrical harness, or Flex Hose that might interfere with the safe operation of the vehicle. Make sure that you cycle the windshield Wipers to insure proper clearance of mechanism.

Reinstall the Glove box door and Ashtray.

*Glove Box Insert*

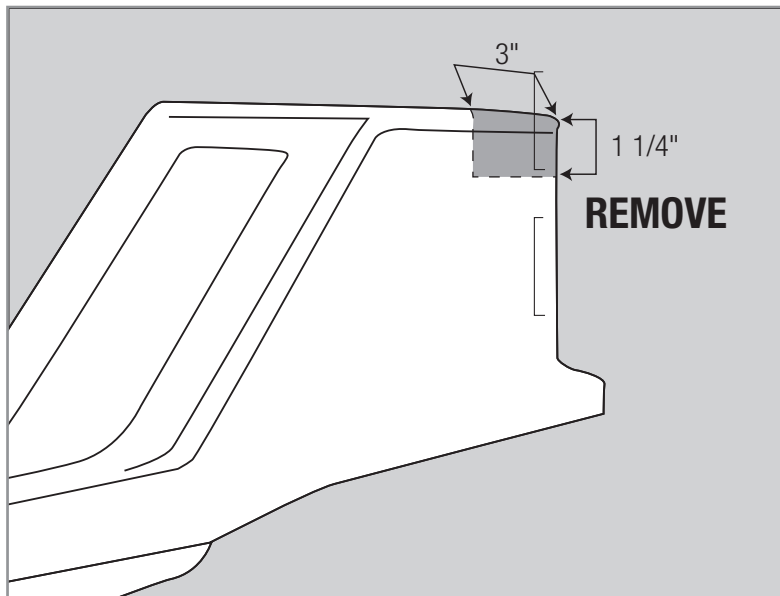

FIGURE 34



**Retaining all the non-resintalled OEM parts is a good idea, but that's your choice.**

If you have any questions before you move on the final phase of this installation, call us.

**888.791.6384**

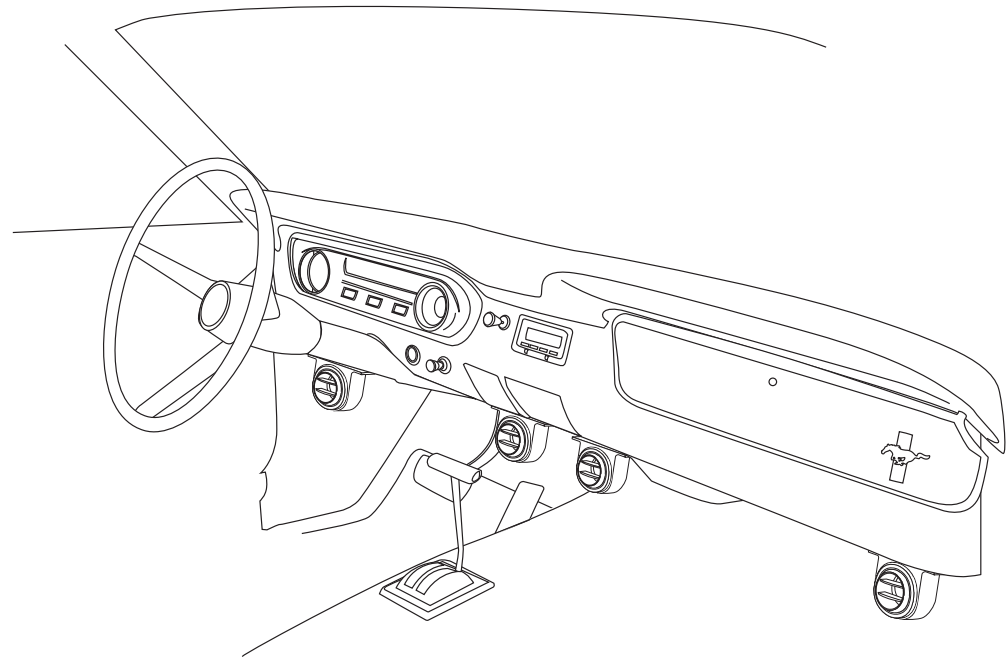

If your vehicle was equipped with a center console (which you removed earlier), you may need to modify it as shown (see figure 34) and reinstall. Test fit your console first.

This completes the interior portion of the PERFECT FIT-ELITE installation process. This is a good time to make a final check that all the controls still move freely and that nothing is loose or hanging down.

The interior of your car should look pretty much the same as before you started (or better). Plus you probably got to know the underside of your dash a lot better and might even have repaired or upgraded components that needed attention.

***Good Job... Let's move on to the major components within the engine compartment...***

# THESE ARE THE PARTS YOU WILL NEED FOR THE ENGINE COMPARTMENT INSTALLATION

You'll find all of these parts within the main box

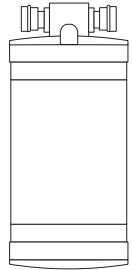

Drier  
PN# 12-1008

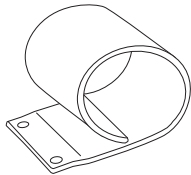

Drier Bracket  
PN# 19-1003

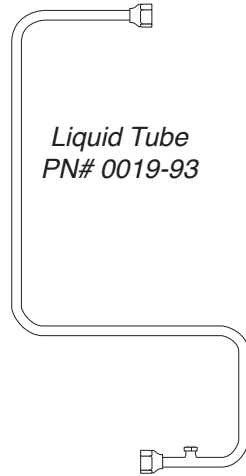

Liquid Tube  
PN# 0019-93

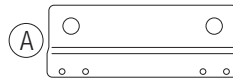

Condenser Brackets  
PN# 0019-53

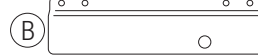

Condenser Brackets  
PN# 0019-52

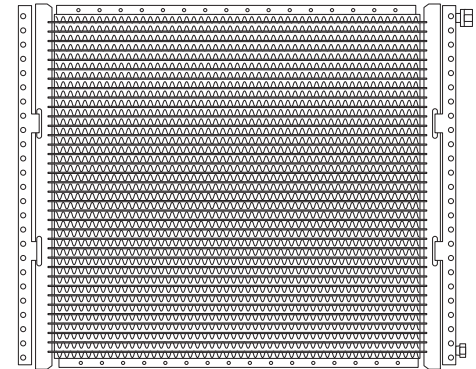

Condenser  
PN# 11-1093

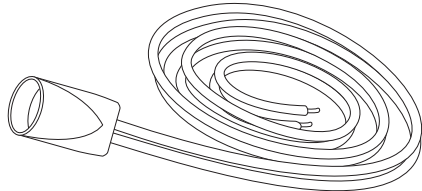

Pressure Switch Harness

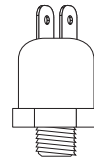

Pressure Switch

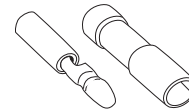

Splice and  
Bullet Connector



Four Zip-Ties

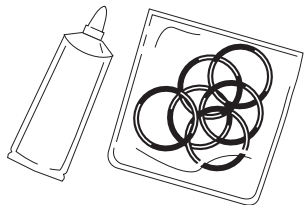

Bag of O-rings and Mineral Oil Tube

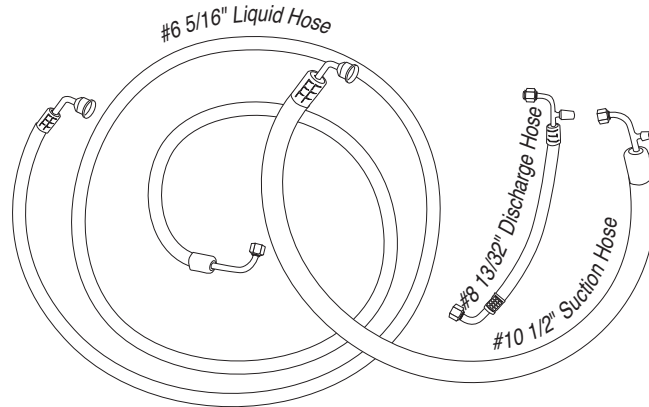

Three Refrigerant Hoses

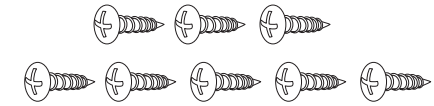

Eight #10 - 20x5/8" Screws



Two #8 - 20 x 5/8" Bolts and Lock Nuts

## ENGINE COMPARTMENT INSTRUCTIONS

**STEP ONE: IF YOU HAVE NOT ALREADY, DISCONNECT THE BATTERY.**

**STEP TWO:** During the next steps you'll be installing the condenser, drier, and routing the high/low pressure lines and the liquid line. Since much of this is installed in the OEM location for the condenser, you'll need to remove the center grill section, horn(s), and latch support assembly (see figure 35). Be sure to retain all the mounting screws – you'll reinstall these pieces in the exact reverse order with the OEM screws.

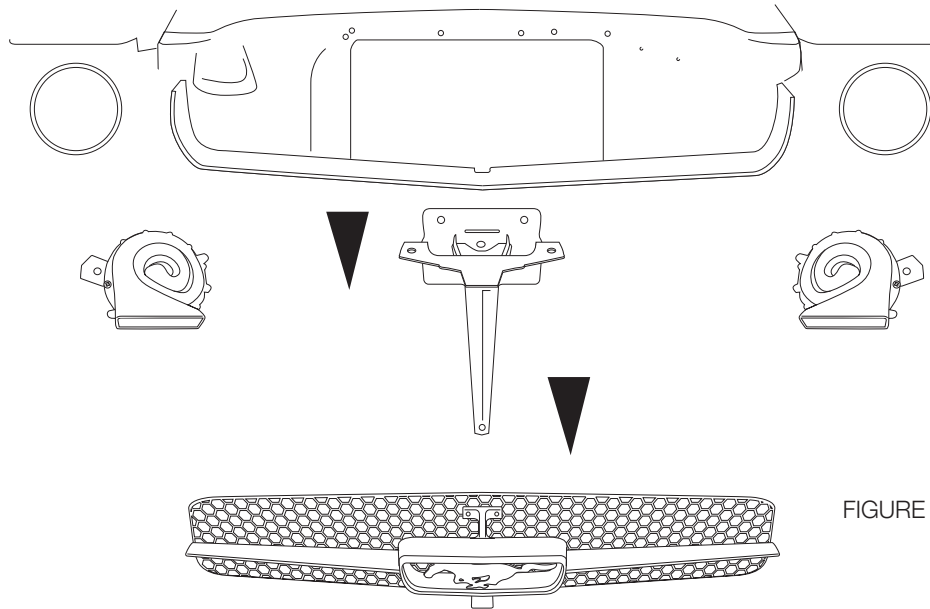
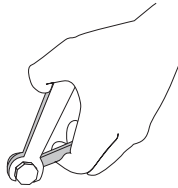

FIGURE 35

**STEP THREE:** Time to install the compressor kit. Included in your box is a premium compressor kit with all the parts you'll need to install the compressor. This kit includes easy to follow instructions specifically written for your engine. Once you've installed the complete compressor kit, continue on to the next step. We believe that this is the finest compressor kit available, and you're bound to notice the excellent fit and quality once this step is completed.



**Reminder...**  
Use two  
wrenches to  
tighten o-ring  
fittings



**STEP FOUR: DRIER AND CONDENSER PREPARATION:** You can perform most of the following steps on a clean flat surface like a workbench. Lay the condenser down so that both hose connections are on the right side (the larger connection will be on top). The drier is conveniently mounted on the right hand side of the condenser. First insert the drier into the drier mounting bracket (it's basically a sleeve for the drier). Attach using the two #8 - 20 x 5/8" Bolts and Lock Nuts, making sure that the drier bracket is bolted to the condenser from the backside. Tighten connections at either end using supplied o-rings on both ends and a few drops of mineral oil to each o-ring.

**STEP FIVE:** Screw the high-pressure switch into the port at the lower end of the drier liquid tube. Go ahead and plug the pressure switch harness into the switch at this time (black electrical boot with two long white wires).

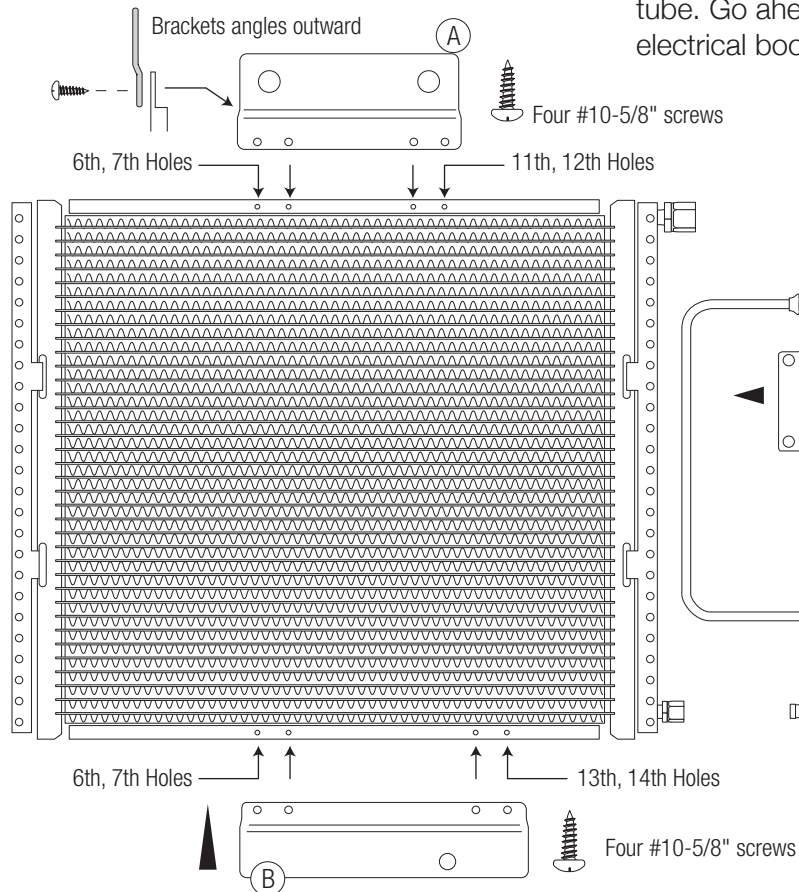

**STEP SIX:** Install the upper condenser bracket (A) using four #10 - 20 x 5/8 screws in the 6th, 7th, 11th and 12th holes on the condenser from the left, be sure the bend on the bracket is facing towards you. Next, attach the lower bracket (B) using four #10-20x5/8 screws in the 6th, 7th, 13th and 14th hole from the left hand side. This bracket has a large hole that corresponds to the OEM latch support previously removed from the vehicle.



You can easily find the correct position for mounting the drier to the condenser by using the drier liquid tube as a gauge.

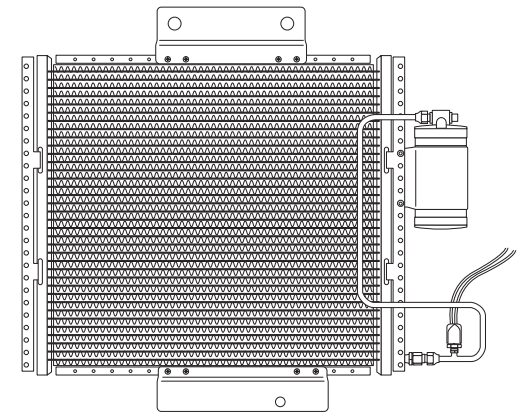

Final Configuration

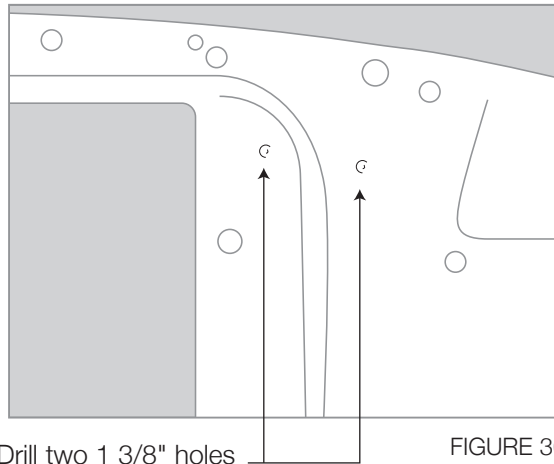

FIGURE 36

**STEP SEVEN:** Your OEM radiator support was designed to support a A/C condenser and conveniently has two small indentations on the drivers side for drilling the holes needed for this part of the installation (see figure 36, *aftermarket core supports may or may not have these indentations*). If your vehicle was already equipped with a OEM A/C, one of these holes may already be drilled. Locate these two small indentations and drill a 1 3/8" hole thru each (be sure to check for any obstructions before drilling, and remove any sharp burrs from the drilling before continuing, see figure 36). You'll notice that the hole closest to the upper condenser fitting is level with the connection fitting (the discharge hose to the compressor will go thru this hole). The other hole is to accommodate the liquid hose and the wiring harness plug for the high-pressure switch.

**STEP EIGHT:** Place the condenser/drier unit into place, locating it so that the holes in the condenser brackets align with the holes in the core support used to attach the hood latch (it will rest on the lower radiator core brace, see figure 37).

#### CONNECTING THE HOSES:

**1) Attach** the #8 Discharge Hose (13/32") to the upper connection of the condenser and route thru the hole previously drilled in the core support and route to the compressor. Tighten fittings using o-rings and mineral oil provided.

**2) Attach** the #6 liquid hose (5/16") to the drier and route thru the remaining hole previously drilled into the core support and along the underside of the fenderbraces and behind the engine to the connection at the firewall on the evaporator unit. **Using supplied zip-ties you'll attach this hose, the suction hose and the lead from the high pressure switch to the strut braces, securing all three at once. For attachment route, see figure 37 on next page.** Tighten fittings using o-rings and mineral oil supplied in kit.

**3) Attach** the #10 suction hose (1/2") to the compressor and route as mentioned above. Tighten fittings using o-rings and mineral oil supplied in the kit.

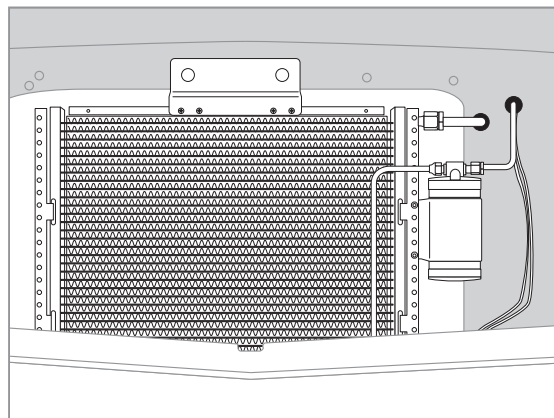

FIGURE 37



If you want to verify that you have the correct indentations in sight before drilling, place fit the condenser into its final location. Also, the holes on the upper bracket are larger than needed to allow for small adjustments. The condenser is held in place when the hood latch is reinstalled at a later time.

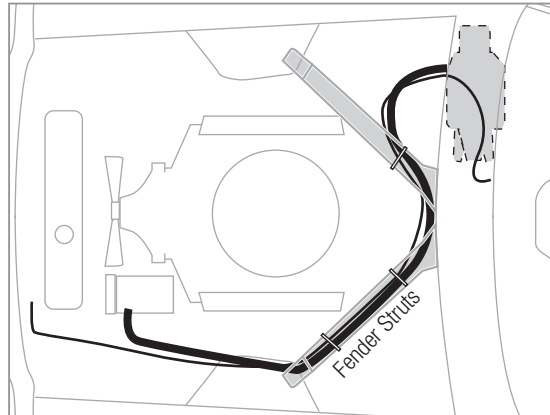

FIGURE 37

**STEP NINE:** Connecting the wires from the pressure switch will be done as follows, connect one wire to the connection on the compressor, and the other wire will be routed along with the liquid hose along the underside of the fender supports and connected to the blue lead you put thru the firewall during the interior installation. We've included a bullet and slice connector to make these connections, use a crimp tool to secure these properly (for attachment route, see figure 37).

**FINAL STEPS:** You can now complete this portion of the installation by reinstalling the grill, horns, and latch support in reverse order. NOTE: The OEM screws for the hood latch support will hold your new condenser in place, so be sure to fully tighten these during this step. Take a look around at your installation and check all fitting and bolts for tightness, check the heater hose clamps for tightness, and make sure nothing is routed in a way to obstruct any moving parts. You can refill the radiator and reconnect the battery at this time.

***WAY TO GO! You've just completed the installation of your new A/C system.***

***The final step is to fully charge and test your new system.***

***On the next page you'll find specifications for proper final preparation for your A/C technician.***

## New A/C System Preparation... A MUST READ!

Please read thru these procedures before completing this new A/C system charging operation.

**A licensed A/C technician should be utilized for these procedures to insure that your new system will perform at it's peak, and that your compressor will not be damaged.**

- 1) Your radiator/cooling system is an integral part of your new system. Please insure that you have a 50/50 mix of distilled water and antifreeze. The heater coil **MUST** be purged (cycle heater control valve) to make sure no water, without antifreeze, is in the heater coil before you charge the A/C system.
- 2) Evacuate the system for 45 minutes (minimum).
- 3) **Your new compressor MUST be hand-turned 15-20 revolutions before and after charging with liquid. Failure to do this may cause the reed valves to become damaged** (this damage is NOT covered by your warranty).
- 4) Your new system requires 134a refrigerant. It will require 1.5 lbs (or 24 oz).
- 5) Your new compressor comes charged with oil - NO additional oil is needed.
- 6) Insure that the new belt is tight.
- 7) **DO NOT CHARGE SYSTEM WITH LIQUID WHILE THE ENGINE IS RUNNING!**

**RECOMMENDED TEST CONDITIONS:** (After system has been fully charged and tested for basic operation)

- Determine the temperature outside of the car
- Connect gauges or service equipment to high/low charging ports
- Place blower fan switch on medium
- Close all doors and windows on vehicle
- Place shop fan directly in front of condenser
- Run engine idle up to approx. 1500 rpm

**ACCEPTABLE OPERATING PRESSURE RANGES:**

1. HIGH-SIDE PRESSURES (150-250 PSI)
2. LOW-SIDE PRESSURES (15-25 PSI in a steady state)

Readings above are based on an ambient temperature of 90° with an adequate airflow on condenser

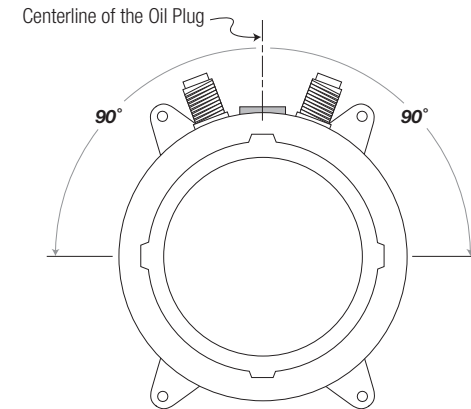

**CAUTION!** When mounting your compressor and/or adjusting the belt, use caution not to tilt the compressor up to or more than 90° off the centerline of the oil fill plug. This can cause compressor failure.

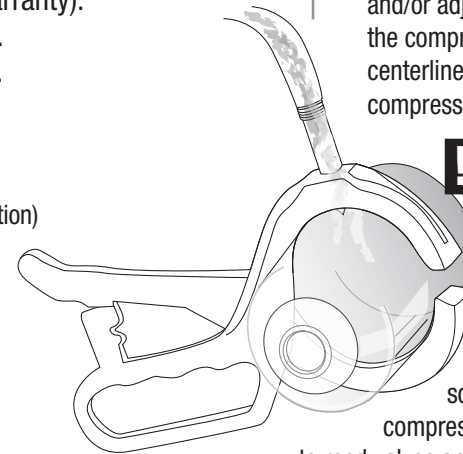

**Do NOT tilt, shake or turn refrigerant can upside-down OR use a charging station to install refrigerant while the engine is running.** Doing

so will direct liquid refrigerant into the compressor piston chamber, causing damage to reed valves and/or pistons and/or other components, as well as potentially seizing the compressor. Allow a minimum of 30 minutes for liquid to "boil off." You must hand turn the compressor hub (not the pulley) a minimum of 15 complete revolutions prior to starting the engine with the clutch engaged.



## TROUBLESHOOTING GUIDE

### TEST CONDITIONS USED TO DETERMINE SYSTEM OPERATION

(THESE TEST CONDITIONS WILL SIMULATE THE AFFECT OF DRIVING THE VEHICLE AND GIVE THE TECHNICIAN THE THREE CRITICAL READINGS THAT THEY WILL NEED TO DIAGNOSE ANY POTENTIAL PROBLEMS).

- B. CONNECT GAUGES OR SERVICE EQUIPMENT TO HIGH/LOW CHARGING PORTS.
- C. PLACE BLOWER FAN SWITCH ON MEDIUM.
- D. CLOSE ALL DOORS AND WINDOWS ON VEHICLE.
- E. PLACE SHOP FAN IN FRONT OF CONDENSER.
- F. RUN ENGINE IDLE UP TO 1500 RPM.

### ACCEPTABLE OPERATING PRESSURE RANGES (R134A TYPE)

1. HIGH-SIDE PRESSURES ( 150-250 PSI ) *\*Note- general rule of thumb is two times the ambient (daytime) temperature, plus 15-20%.*
2. LOW-SIDE PRESSURES ( 15-25 PSI in a steady state).

**CHARGE AS FOLLOWS: R134A = 24 OZ.**

**NO ADDITIONAL OIL IS NECESSARY IN OUR NEW COMPRESSORS.**

### TYPICAL PROBLEMS ENCOUNTERED IN CHARGING SYSTEMS

**NOISY COMPRESSOR.** A noisy compressor is generally caused by charging a compressor with liquid or overcharging

- A. If the system is overcharged both gauges will read abnormally high readings. This is causing a feedback pressure on the compressor causing it to rattle or shake from the increased cylinder head pressures. System must be evacuated and re-charged to exact weight specifications.
- B. **Heater control valve installation** - Installing the heater control valve in the incorrect hose. Usually when this occurs the system will cool at idle then start to warm up when raising the RPM's of the motor. **THE HEATER CONTROL IS A DIRECTIONAL VALVE; MAKE SURE THE WATER FLOW IS WITH THE DIRECTION OF THE ARROW.** As the engine heats up that water transfers the heat to the coil, thus overpowering the a/c coil. A leaking or faulty valve will

have a more pronounced affect on the unit's cooling ability. Installing the valve improperly (such as having the flow reversed) will also allow water to flow through, thus inhibiting cooling. Check for heat transfer by disconnecting hoses from the system completely. By running down the road with the hoses looped backed through the motor, you eliminate the possibility of heat transfer to the unit.

- C. **Evaporator freezing** - Freezing can occur both externally and internally on an evaporator core. External freeze up occurs when the coil cannot effectively displace the condensation on the outside fins and the water forms ice (the evaporator core resembles a block of solid ice), it restricts the flow of air that can pass through it, which gives the illusion of the air not functioning. The common cause of external freezing is the setting of the thermostat and the presence of high humidity in the passenger compartment. All door and window seals should be checked in the event of constant freeze-up. A thermostat is provided with all units to control the cycling of the compressor.
- D. **Internal freeze up** occurs when there is too much moisture inside the system. The symptoms of internal freeze up often surface after extended highway driving. The volume of air stays constant, but the temperature of the air gradually rises. When this freezing occurs the low side pressure will drop, eventually going into a vacuum. At this point, the system should be checked by a professional who will evacuate the system and the drier will have to be changed.
- E. **Inadequate airflow to condenser** - The condenser works best in front of the radiator with a large supply of fresh air. Abnormally high pressures will result from improper airflow. Check the airflow requirements by placing a large capacity fan in front of the condenser and running cool water over the surface. If the pressures drop significantly, this will indicate the need for better airflow.
- F. **Incorrect or inadequate condenser capacity** - Incorrect condenser capacity will cause abnormally high head pressures. A quick test that can be performed is to run cool water over the condenser while the system is operating, if the pressures decrease significantly, it is likely a airflow or capacity problem.
- G. **Expansion valve failure** - An expansion valve failure is generally caused by dirt or debris entering the system during assembly. If an expansion valve fails it will be indicated by abnormal gauge readings. A valve that is blocked will be indicated by high side that is unusually high, while the low side will be unusually low or may even go into a vacuum. A valve that is stuck open will be indicated by both the high and low pressures rising to unusually high readings, seeming to move toward equal readings on the gauges.
- H. **Restrictions in system** - A restriction in the cooling system will cause abnormal readings on the gauges. A high-side restriction ( between the compressor and the drier inlet ) will be indicated by the discharge gauges reading excessively high. These simple tests can be performed by a local shop and can help determine the extent of the systems problem.

## Trouble Shooting Your Classic Auto Air A/C System

**PROBLEM: system is not cooling properly**

**ISSUE: cold at idle, warmer when raising engine RPM's**

### **Make sure the Water Valve is positioned correctly**

The water valve is a directional valve and should be installed with the arrow pointing towards the water pump, it should be connected to the heater hose that runs from the heater core to the water pump. If the water valve is connected to the incorrect hose it allows water to circulate through the system via the heater core over powering the cooling effect of the A/C coil, (normally the air conditioning is functioning properly).

**Step 1:** Check placement of the water valve, correct if needed. (In some cases changing the location of the water valve may not fix the above problem.) Continue to next step.

**Step 2** If changing the location of the water valve does not rectify the issue, then possibly the water valve is permanently damaged and may need to be replaced. To check the integrity of the water valve completely remove the water hoses for the heater core and "loop" together. (This will remove the heater system completely from the possibilities) If the system now cools, replace the water valve

### **Verify Adequate Air Flow to Condenser**

For an air conditioning system to function properly there has to be adequate airflow across the condenser. The function of the condenser is to dissipate heat, without proper airflow your system will not cool correctly in the cabin of your vehicle.

**Step 1:** connect gauges to a/c hoses. The pressures should be: with the ambient temp is 90, low side pressures should be between 8-25 psi, high side pressures should be between 160-260psi

**Step 2:** IF the low side pressures are normal and the high side pressures are high then there might be an airflow issue, continue to next step.

### **To test air flow to Condenser do the following three tests:**

1. Place a piece of paper on the condenser with the car in idle and see if paper is held in place.
2. With car in idle, attach gages, and place a large capacity fan in front of the condenser. What happens to the pressures?
3. With car still in idle and gages attached, pour water down the front of the condenser. What happens to the pressures?

If the paper is held in place you are at least getting some air flow. If the high side decreases during test 2 & 3 then your condenser is not getting enough air which is causing your system to not cool properly. To correct this issue you will need a more powerful mechanical fan.

### **Step 3: Confirm correct Refrigerant charge in System**

All of our systems should be charged with 24oz or 1.8lbs of R134 Refrigerant only. If overcharged you will need to evacuate the system and recharge with the correct amount.\*

### **What measurements mean:**

Low Temp and High Pressure seem to be equal...

You have a malfunctioning expansion valve that is stuck open.

High Side is extremely high and Low Side is extremely low (possibly into vacuum)...

There is a blockage in the system. Remove hoses and blow compressed air through in both directions. If pressures don't change its possible that your expansion valve is stuck closed and would have to be replaced.

### **\*Compressor Concerns:**

This is often misdiagnosed as a problem for the system not cooling properly. If you have a noisy compressor it is due to improper charging of refrigerant. An overcharged (more than 24oz or 1.8lbs R134) compressor can cause rattling. If charged with pure liquid there is a high probability you have bent reed valves that are causing tapping sound.



**IF YOU PRINTED THIS MANUAL  
PLEASE READ THIS...**

Just as a cautionary step, please measure this box and make sure it is 1" x 1". Some copiers/printers may not print at 100% of actual size.

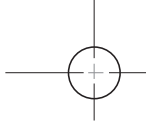
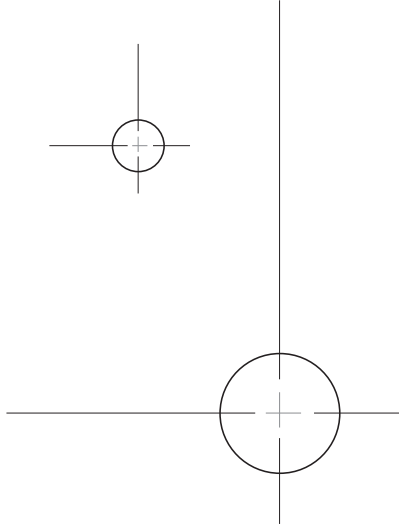

Note: bottom of template is parallel with floor pan



